

Subminiature DVRT[®]

Differential Variable Reluctance Transducer



Introduction

Ideal for linear control & precision measurement applications, the sub-miniature DVRT[®] features a fast response and rugged packaging. The sensing head is also capable of total submersion in aqueous environments.

Features of our sub-miniature DVRT[®]s include micron resolution, linear analog output, flat dynamic response to kHz levels, and very low temperature coefficients. Free sliding transducer cores are lightweight, strong, and corrosion resistant. Cores are precision ground to insure a close sliding fit within the open bore of the stainless-steel lined DVRT[®] body. This precision fit allows the DVRT[®] to achieve extremely high repeatability. Custom strokes are also available.

Miniature “plug and play” signal conditioners provide linear DC output when supplied with unregulated DC power. Multi-channel, OEM and digital display systems are also available.

Features & Benefits

- available with sub-micron resolution and long stroke range
- operating temperature to 175 °C
- frequency response up to 20 kHz
- lightweight core will not influence frequency response
- stainless steel and high-performance polymer design suitable for extremely harsh environments
- waterproof, suitable for short term submersion in corrosive media such as brake fluid and hot saline
- frictionless design suitable for high duty-cycle applications
- easily customized to suit specific application

Applications

- miniature control elements for automotive and robotic systems
- process control for production-line monitoring
- dimensional gauging for quality control applications
- measuring strain and deflection in materials science and civil structures
- linear/angular positioning of optical components
- miniature force, torque, acceleration sensors



How it works

Core position is detected by measuring the coils' differential reluctance, using a sinewave excitation and synchronous demodulator. This differential detection method provides a very sensitive measure of core position while cancelling out temperature effects.

The transducers' coils and flex circuit leads are sealed in vacuum-pumped epoxy, within the stainless-steel case. This provides outstanding environmental resistance. The sub-miniature DVRT® has been successfully employed in harsh applications, including short term immersion in saline and pressurized oil.*

Differential Variable Reluctance Transducer

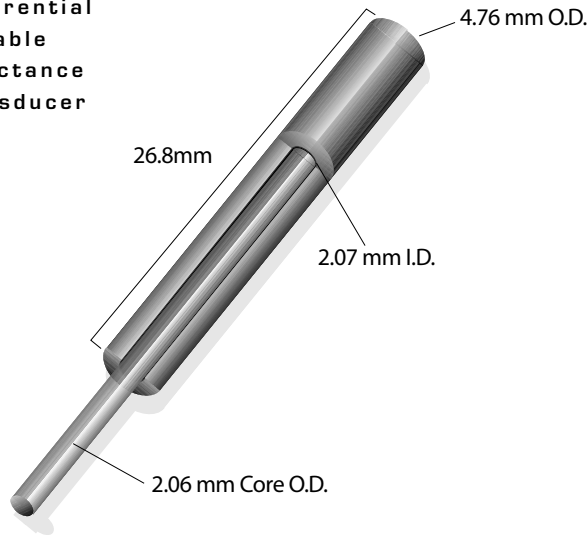

Electrical Specifications

(obtained using MicroStrain®'s DEMOD-DVRT®)

Linear Stroke Lengths	4, 8, 24, 38 mm (standard resolution) 6 mm (high resolution) 500 µm or less (nano resolution)
Accuracy*	± 1.0 % using straight line ± 0.1 % using polynomial
Sensitivity	1 volt/mm typical (for 8 mm stroke)
Signal to noise (using DEMOD-DVRT®)	4200 to 1 (with filter 3 dB down at 800 Hz, standard resolution), 466 to 1 (unfiltered)
Resolution (0.025% of full scale for standard version)	1.0 µm for 4 mm stroke 2.0 µm for 8 mm stroke 6.0 µm for 24 mm stroke 9.5 µm for 38 mm stroke 0.6 µm for high resolution version 10 nm for nano resolution version
Frequency response	800 Hz standard, 20 KHz optional
Temperature coefficient	offset 0.002% / °C (typical) span 0.030% / °C (typical)
Hysteresis*	± 1 micron
Repeatability*	± 1 micron

* at constant temperature

Mechanical Specifications

Overall body length	18.5 mm for 4 mm stroke 34.5 mm for 8 mm stroke 81 mm for 24 mm stroke 124 mm for 38 mm stroke 34.5 mm for high res version 34.5 mm for nano version
Outside diameter	4.76 mm (3/16 inch)
Housing material	300 stainless steel, smooth 5/16 - 24 threaded 400 stainless steel (optional)
Attachment method	optional: magnetic mounting block, threaded body, clamping collar
Leadouts	45 cm multistrand, shielded, stainless steel reinforced teflon insulated cable
Connector	keyed 4 pin Lemo
Operating temperature	-55 to 175 °C
Core weight	500 µm: 0.04 g, 4 mm: 0.04 g, 8 mm: 0.04 g, 24 mm: 1.62 g, 38 mm: 1.67 g
Cable diameter	0.070"

U.S. Patent No. 4,813,435; 5,497,147; 5,777,467

*Units available for long term submersion can be custom built to meet specific application requirements