

2

1

REV	DESCRIPTION	DATE	APPROVED

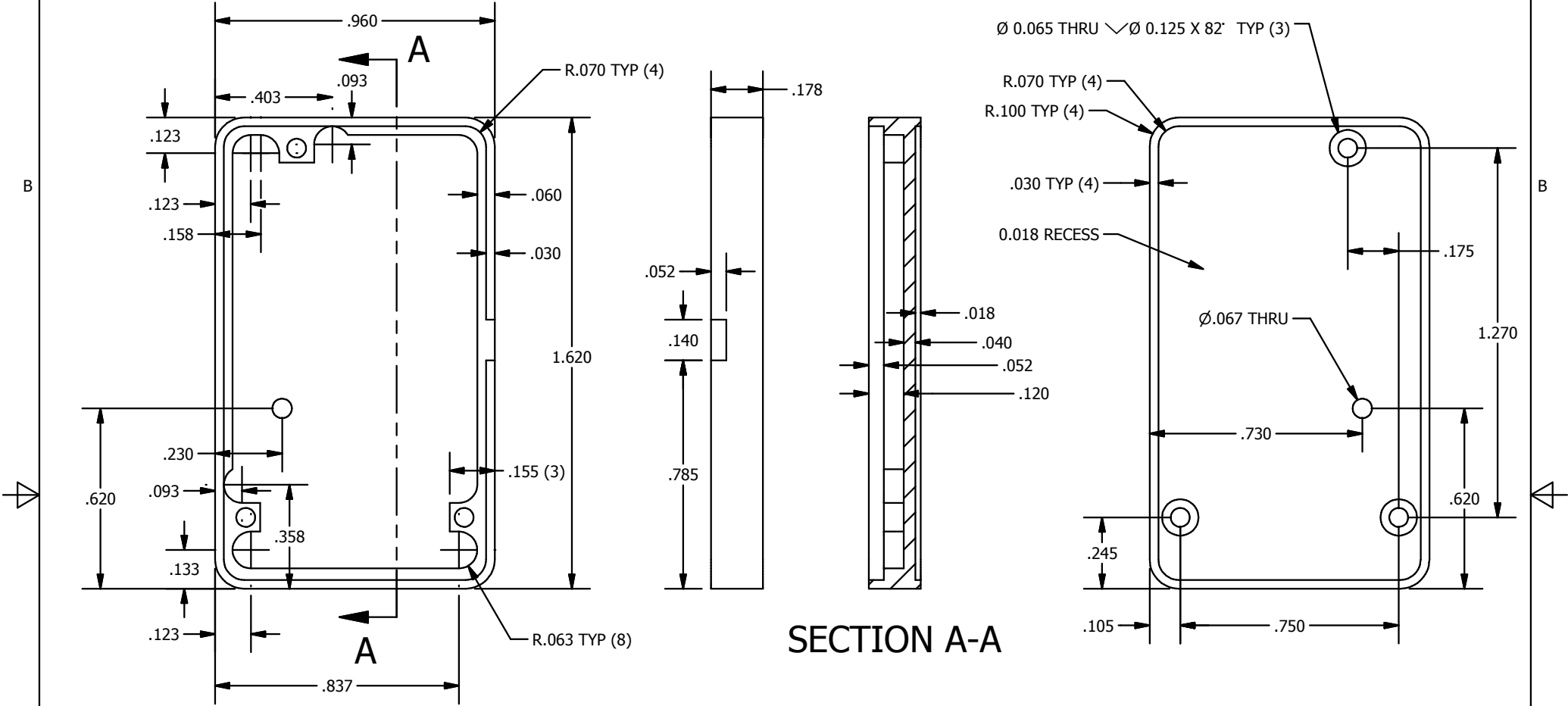

SECTION A-A

UNLESS OTHERWISE SPECIFIED ALL DIMENSIONS ARE IN INCHES.
 TOLERANCES:(UOS):
 .X = ± .02; .XX = ± .01; .XXX = ± .005
 HOLE DIAMETERS: ± .002; ANGLES: ± 0.5°
 SURFACE FINISH: 63 MICROINCHES
 MATERIAL: ALUMINUM
 FINISH: BLACK ANODIZED

MicroStrain® 459 Hurricane Lane, Suite 102
 Williston, VT 05495
 802-862-6629

TITLE
ENCLOSURE, ISD2-05, LID

THIS DRAWING AND SPECIFICATIONS ARE THE PROPERTY OF MICROSTRAIN INC. AND SHALL NOT BE PRODUCED WITHOUT PERMISSION FROM MICROSTRAIN INC.

DESIGNED BY: GCK
 DRAWN BY: RGL
 CHECKED BY:
 APPROVED BY: RGL

SIZE A	CAGE CODE OXYZ9	DWG NO: 3065-7046	REV 000
SCALE 2:1		DATE: 9/30/2009	SHEET 1 OF 2

2

1

2

1

REV	DESCRIPTION	DATE	APPROVED

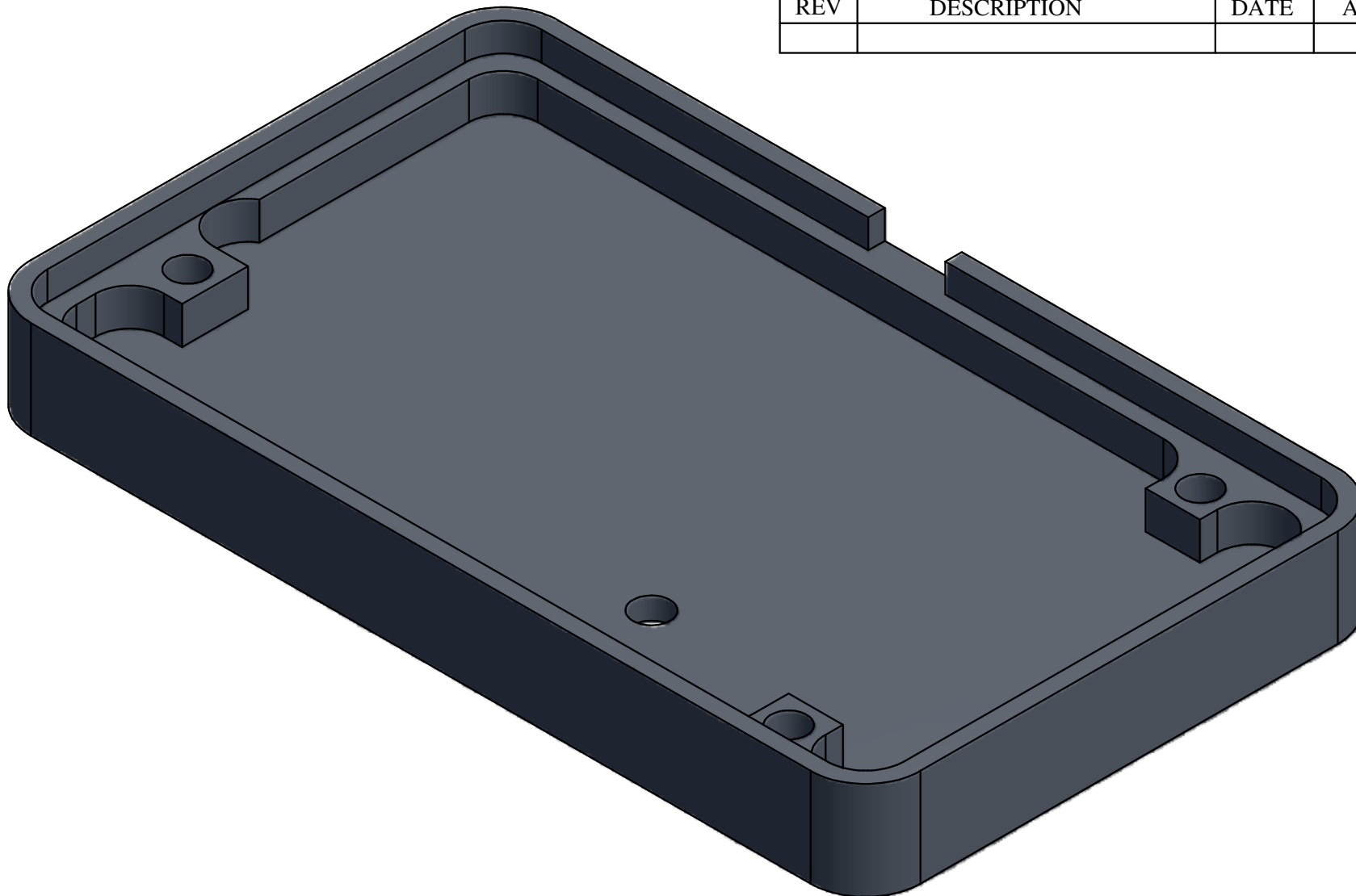

UNLESS OTHERWISE SPECIFIED ALL DIMENSIONS ARE IN INCHES.
 TOLERANCES:(UOS):
 .X = ± .02; .XX = ± .01; .XXX = ± .005
 HOLE DIAMETERS: ± .002; ANGLES: ± 0.5°
 SURFACE FINISH: 63 MICROINCHES
 MATERIAL:



459 Hurricane Lane, Suite 102
 Williston, VT 05495
 802-862-6629

TITLE
ENCLOSURE,ISD2-05,LID

THIS DRAWING AND SPECIFICATIONS ARE THE PROPERTY OF MICROSTRAIN INC. AND SHALL NOT BE PRODUCED WITHOUT PERMISSION FROM MICROSTRAIN INC.

DESIGNED BY:	DRAWN BY: RGL
CHECKED BY:	APPROVED BY: RGL

SIZE A	CAGE CODE OXYZ9	DWG NO: 3065-7046	REV 000
-----------	--------------------	----------------------	------------

SCALE 5:1	DATE: 9/30/2009	SHEET 2 OF 2
-----------	-----------------	--------------

2

1