

2

1

REV	DESCRIPTION	DATE	APPROVED

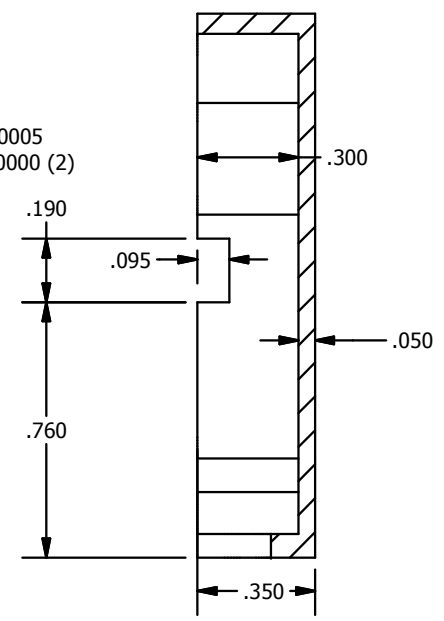
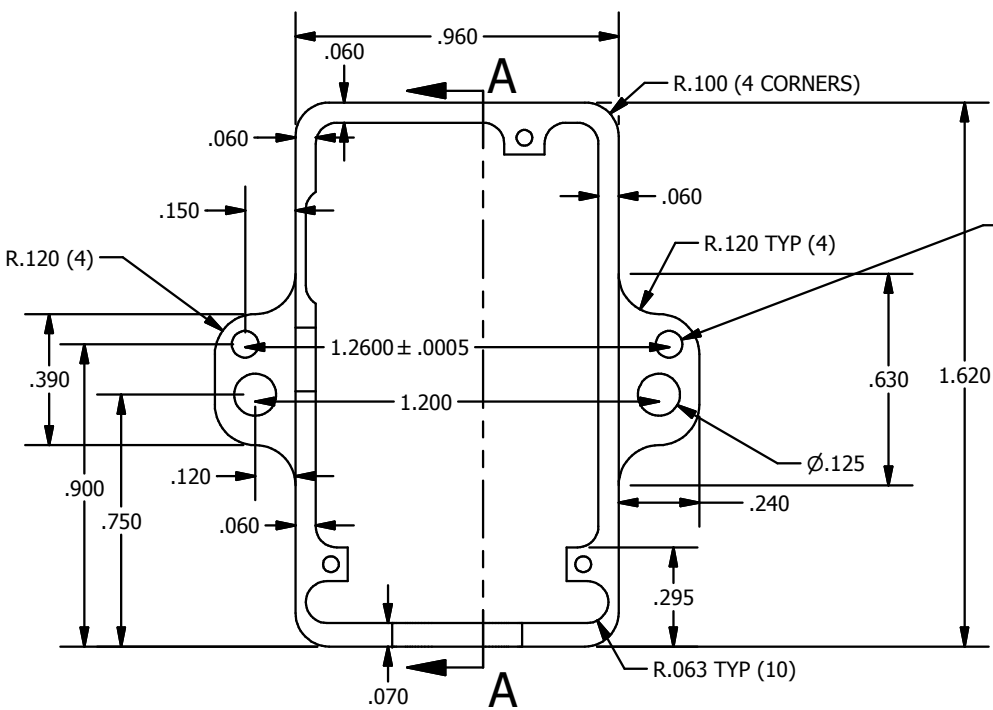

SECTION A-A

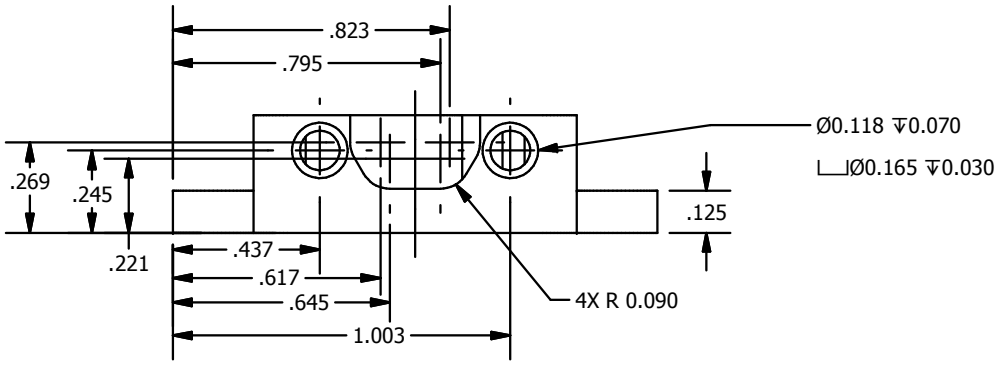

UNLESS OTHERWISE SPECIFIED ALL DIMENSIONS ARE IN INCHES.
 TOLERANCES:(UOS):
 .X = ± .02; .XX = ± .01; .XXX = ± .005
 HOLE DIAMETERS: ± .002; ANGLES: ± 0.5°
 SURFACE FINISH: 63 MICROINCHES
 MATERIAL: ALUMINUM
 FINISH: BLACK ANODIZED

MicroStrain[®] 459 Hurricane Lane, Suite 102
 Williston, VT 05495
 802-862-6629

TITLE
ENCLOSURE, ISD2-05, BASE

THIS DRAWING AND SPECIFICATIONS ARE THE PROPERTY OF MICROSTRAIN INC. AND SHALL NOT BE PRODUCED WITHOUT PERMISSION FROM MICROSTRAIN INC.

DESIGNED BY: **GCK**
 DRAWN BY: **RGL**
 CHECKED BY: **RGL**
 APPROVED BY: **RGL**

SIZE A	CAGE CODE OXYZ9	DWG NO: 3065-7045	REV 000
SCALE 1.75:1		DATE: 9/30/2009	SHEET 1 OF 2

2

1

2

1

REV	DESCRIPTION	DATE	APPROVED

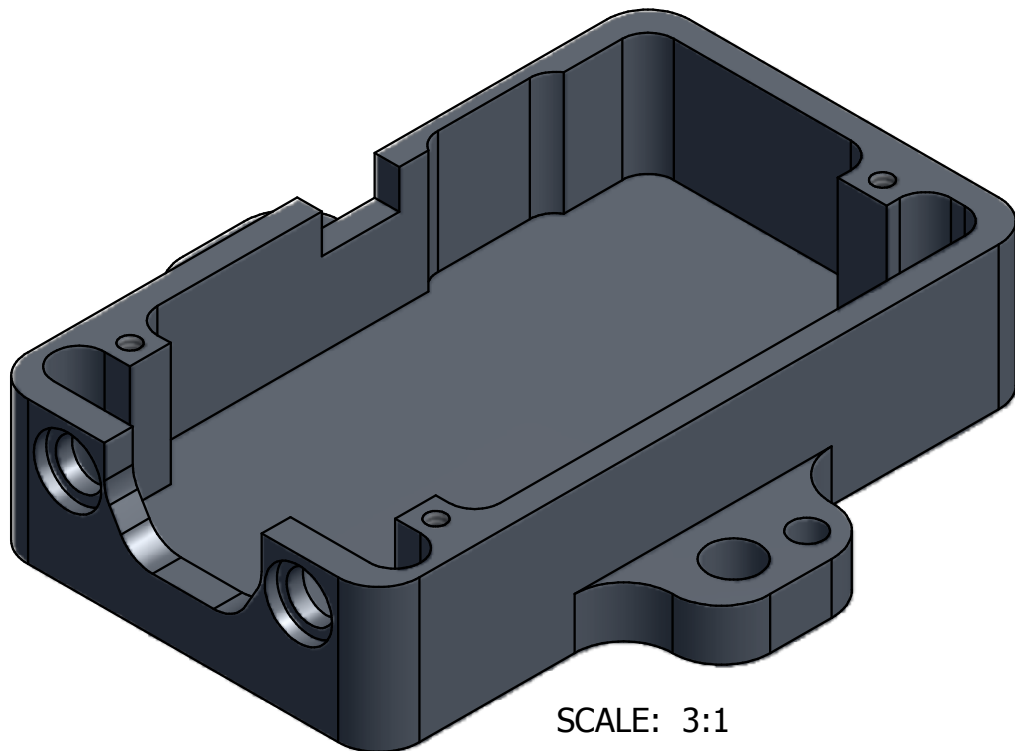
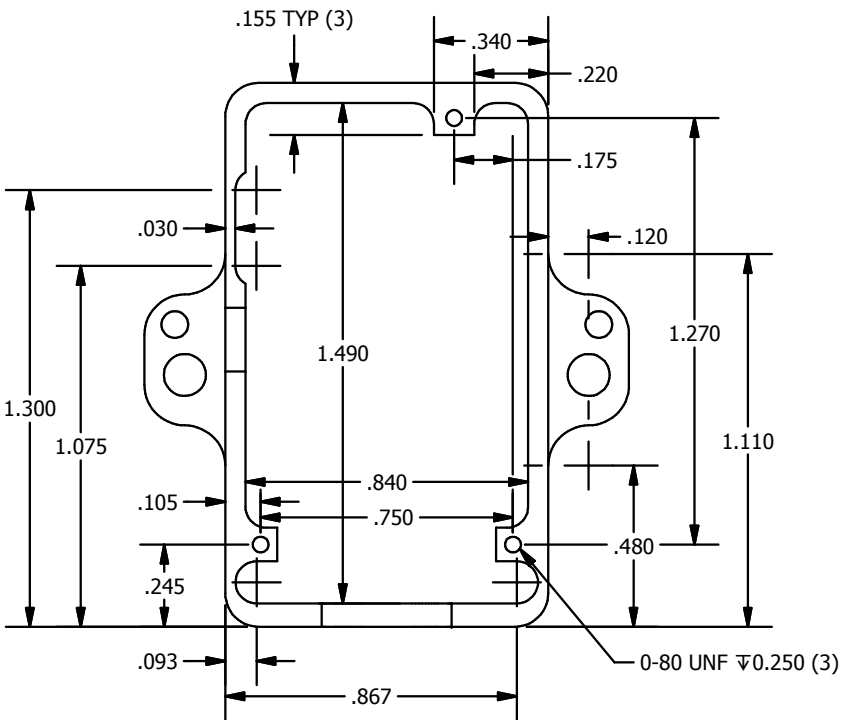

SCALE: 3:1

UNLESS OTHERWISE SPECIFIED ALL DIMENSIONS ARE IN INCHES.
 TOLERANCES:(UOS):
 .X = \pm .02; .XX = \pm .01; .XXX = \pm .005
 HOLE DIAMETERS: \pm .002; ANGLES: \pm 0.5°
 SURFACE FINISH: 63 MICROINCHES
 MATERIAL:



459 Hurricane Lane, Suite 102
 Williston, VT 05495
 802-862-6629

TITLE
ENCLOSURE,ISD2-05,BASE

THIS DRAWING AND SPECIFICATIONS ARE THE PROPERTY OF MICROSTRAIN INC. AND SHALL NOT BE PRODUCED WITHOUT PERMISSION FROM MICROSTRAIN INC.

DESIGNED BY: **GCK**
 DRAWN BY: **RGL**
 CHECKED BY:
 APPROVED BY: **RGL**

SIZE A	CAGE CODE OXYZ9	DWG NO: 3065-7045	REV 000
SCALE 1.75:1		DATE: 9/30/2009	SHEET 2 OF 2

2

1