

G-Link[®]

Wireless Accelerometer Node



©2011 by MicroStrain, Inc.
459 Hurricane Lane, Suite 102
Williston, VT 05495
Phone 802-862-6629
Fax 802-863-4093
www.microstrain.com
support@microstrain.com

ISSUED: 20 July 2011

Table of Contents

WELCOME	5
SUPPORTED FIRMWARE AND SOFTWARE VERSIONS	6
GUIDE TO RELEVANT DOCUMENTS	6
OVERVIEW	7
INSTALLATION	8
STARTER KITS, MODULES AND OPTIONS	9
COMMON TERMS	11
OPERATION.....	13
BASE STATIONS	17
USB BASE STATION	17
ANALOG BASE STATION	17
SERIAL BASE STATION	18
ACCELEROMETERS.....	19
GENERAL INFORMATION	19
CONVERSION TO PHYSICAL UNITS.....	19
LOW PASS FILTER/ANTI-ALIASING FILTER	19
TEMPERATURE SENSOR	20
GENERAL INFORMATION	20
CONVERSION TO PHYSICAL UNITS.....	20
LEDS	21
CHARGE POWER GOOD LED	21
CHARGING LED	21
CHARGE COMPLETE LED.....	21
DEVICE STATUS LED	22
RADIO AND ANTENNA	23
NODE ADDRESSING	24
SAMPLE DURATION CALCULATIONS.....	25
TIME STAMPING	26
POWER.....	27
ON/OFF SWITCH.....	27
INTERNAL BATTERY	27
BYPASSING THE INTERNAL BATTERY	28
POWER PROFILE	29
STANDARD ENCLOSURE	30
OPTIONAL ENCLOSURES.....	31
HIGH G OPTION	33
OPERATING TEMPERATURE.....	34
SAMPLING RATES	35

DATALOGGING	35
STREAMING	35
LOW DUTY CYCLE	35
HIGH SPEED STREAMING.....	36
DATALOGGING MEMORY	37
FACTORY CALIBRATION.....	38
GENERAL SPECIFICATIONS	39
MECHANICAL DRAWINGS.....	41
ENCLOSURE DIMENSIONS	41
CIRCUIT BOARD ASSEMBLY DIMENSIONS	42
MEASUREMENT AXES.....	43
CALIBRATION AXES	43
SYSTEM BLOCK DIAGRAM	44
FCC (UNITED STATES) CERTIFICATION	45
LABELING REQUIREMENTS	45
FCC-APPROVED ANTENNAS	45
IMPORTANT NOTES.....	46
IC (INDUSTRY CANADA) CERTIFICATION	47
TRANSMITTER ANTENNAS	47
SOFTWARE	48
STANDARD OFFERING	48
SYSTEM REQUIREMENTS	48
SOFTWARE INSTALLATION	48
DATA COMMUNICATIONS PROTOCOL.....	48
SUPPORT	50
OVERVIEW.....	50
WEB	50
EMAIL.....	50
TELEPHONE	50
SKYPE	50
RMA.....	51
30 DAY RETURN POLICY	52
TERMS AND CONDITIONS.....	53
APPENDIX 1: HOST-TO-BASE STATION COMMUNICATION.....	59
RS-232.....	59
USB 2.0.....	59
APPENDIX 2: DATALOGGING WITH AGILE-LINK™ SOFTWARE	60
APPENDIX 3: STREAMING WITH AGILE-LINK™ SOFTWARE	62
APPENDIX 4: LOW DUTY CYCLE WITH AGILE-LINK™ SOFTWARE.....	64
APPENDIX 5: HIGH SPEED STREAMING WITH HIGH SPEED STREAMING SOFTWARE... 	70

Welcome

Welcome to MicroStrain! We make tiny sensors that are used in a wide range of applications, including knee implants, civil structures, advanced manufacturing, unmanned military vehicles, and automobile engines. Our sensors have won numerous awards and we pride ourselves on being both innovative and responsive to our customer's unique requirements.

MicroStrain is based in Williston, Vermont and is a privately held corporation. Founded in 1987, our early development focused on producing micro-displacement sensors for strain measurement in biomechanics research applications. Our first sensors were designed for arthroscopic implantation on human knee ligaments; since then, we expanded our product line through continual product improvement.

We introduced a broader line of micro-displacement sensors that could withstand extreme temperatures, hundreds of millions of cycles, and complete submersion in saline. The aerospace and automotive industry found our sensing systems met their requirements and we've worked on many groundbreaking projects.

As our customer base expanded, we continued to innovate by combining multiple sensors along with advanced micro controllers to enhance system performance. We were one of the first sensor companies to add wireless capability so that low power, miniature digital sensors could communicate easily with personal computers and send data to the internet.

Our inclinometer product line was initially developed to measure angles of limbs to help re-animate the limbs of paralyzed individuals. The tiny, lightweight gyro-enhanced orientation modules that resulted from this effort found immediate acceptance for navigation & control of unmanned systems in military and exploratory robotics applications.

Sensors are literally changing our world; we're inspired to work with our customers to introduce advanced sensing technology that will enable the next generation of smarter and safer machines, civil structures, and implanted devices.

Thank you for purchasing a MicroStrain sensor!

Steve Arms
President and CEO, MicroStrain, Inc.

Supported Firmware and Software Versions

Device	Firmware version	Software version
V-Link®	4.99 and higher	Agile-Link™ 1.4.1 and higher
SG-Link®	4.99 and higher	Agile-Link™ 1.4.1 and higher
G-Link®	4.99 and higher	Agile-Link™ 1.4.1 and higher
TC-Link®	4.99 and higher	Agile-Link™ 1.4.1 and higher
USB Base Station	2.0.7 and higher	Agile-Link™ 1.4.1 and higher
Analog Base Station	2.0.7 and higher	Agile-Link™ 1.4.1 and higher
Serial Base Station	2.0.7 and higher	Agile-Link™ 1.4.1 and higher

Table 1

Guide to Relevant Documents

Wireless Node	Document
V-Link®	Agile-Link™ Software Manual
V-Link®	V-Link® Quick Start Guide
V-Link®	V-Link® User Manual
V-Link®	Base Station User Manual
V-Link®	High Speed Streaming Quick Start Guide
SG-Link®	Agile-Link™ Software Manual
SG-Link®	SG-Link® Quick Start Guide
SG-Link®	SG-Link® User Manual
SG-Link®	Base Station User Manual
SG-Link®	High Speed Streaming Quick Start Guide
G-Link®	Agile-Link™ Software Manual
G-Link®	G-Link® Quick Start Guide
G-Link®	G-Link® User Manual
G-Link®	Base Station User Manual
G-Link®	High Speed Streaming Quick Start Guide
TC-Link®	TC-Link® Quick Start Guide (covers Node Monitor)
TC-Link®	TC-Link® User Manual
TC-Link®	Base Station User Manual

Table 2

Overview

The G-Link® is a wireless accelerometer node and is a specialized member of MicroStrain's Agile-Link™ wireless data acquisition system. The Agile-Link™ system comprises 3 main components: 1) wireless sensor nodes which acquire and transmit strain, voltage, temperature, acceleration and/or other sensor data, 2) base stations which receive and pass the data to a host, and 3) software which operates the system.

The G-Link® contains two orthogonally mounted, dual-axis MEMS accelerometers for measuring acceleration X, Y and Z axes. The G-Link® comes either with all +/-2G rated or all +/-10G rated accelerometers. The G-Link® also has an on-board temperature sensor.



The G-Link® employs a 12 bit A/D converter to digitize the accelerometer voltage. The accelerometer digital data is passed to the on-board microprocessor, processed with the embedded algorithm, and in turn either passed to its radio for immediate transmission or saved to the 2MB on-board flash memory for later download.

Host computer software displays the data, provides analysis tools, records the data to file and allows the user to configure and actuate the system. The G-Link® may also be used with MicroStrain's Analog base station for stand-alone applications.

The G-Link® may be deployed up to 70 meters (line-of-sight) from its base station, and 100 meters or more with added antenna options.

The G-Link® has a long life internal battery and may be remotely deployed in any number of applications including bridges, machinery, aircraft, production lines and the like.

Multiple G-Link®'s may be deployed around a single base station, each transmitting its data to the base station coincidentally, with the data being passed on to the software for aggregation.

Installation

We suggest these three steps to install your G-Link®:

- 1) Install the Agile-Link™ software by following the directions given in the *Software Installation* section of this manual.
- 2) Remove the contents of your G-Link® starter kit.
 - Install the antenna on the base station antenna connector. Tighten hand tight; do not over tighten.
 - If you have a serial base station (see **Figure 1**), connect the RS-232 cable to a serial port on your PC and to the serial base station RS-232 connector. Connect the external power supply to the power connector on the serial base station and plug it into a proper power receptacle. Turn the serial base station power switch on and the green LED will illuminate indicating the base station is powered
 - If you have a USB base station, plug the USB connector into any USB port on your PC. The blue LED will illuminate indicating the base station is powered.
 - If you have an analog base station, connect the USB cable to any USB port on your PC and to the analog base station USB connector on the back panel. Connect the external power supply to the power connector on the back panel of the analog base station and plug it into a proper power receptacle. Depress the red power button on the front panel and the green LED will illuminate indicating the base station is powered.
 - Install the antenna on the G-Link® antenna connector. Tighten hand tight; do not over tighten. Insure the G-Link® is turned off (switch towards power connector).
 - Fully charge the G-Link® internal battery following the procedure given in the *Internal Battery* section of this manual.



Figure 1

- 3) Follow the step-by-step instructions in the G-Link® *Quick Start Guide* which you will find on the CD or on our web site.

This will get you up and running. From here you will want to use the Agile-Link™ software to familiarize yourself with all the operations of the G-Link®.

Starter Kits, Modules and Options

The G-Link® is available in starter kits, as individual modules and with options.

Part Number	Model Number	Description
6305-0000	G-LINK-2G-2400-M	G-LINK-2G-2400-M, G-LINK wireless triaxial accelerometer node with ± 2 g range. Operates on 2.4 GHz direct sequence spread spectrum, IEEE 802.15.4 radio.
6305-0011	G-LINK-2G-2400-SKA	G-LINK-2G-2400-SKA, G-LINK starter kit includes one G-LINK wireless triaxial accelerometer node with ± 2 g range, one analog/digital output base station with power supply, charger and Agile-Link software. Operates on 2.4 GHz direct sequence spread spectrum, IEEE 802.15.4 radio.
6305-0041	G-LINK-2G-2400-SK1	G-LINK-2G-2400-SK1, G-LINK starter kit includes one G-LINK wireless triaxial accelerometer nodes with ± 2 g range, one USB base station, charger and Agile-Link software. Operates on 2.4 GHz direct sequence spread spectrum, IEEE 802.15.4 radio.
6305-0042	G-LINK-2G-2400-SK2	G-LINK-2G-2400-SK2, G-LINK starter kit includes two G-LINK wireless triaxial accelerometer nodes with ± 2 g range, one USB base station, charger and Agile-Link software. Operates on 2.4 GHz direct sequence spread spectrum, IEEE 802.15.4 radio.
6305-1000	G-LINK-10G-2400-M	G-LINK-10G-2400-M, G-LINK wireless triaxial accelerometer node with ± 10 g range. Operates on 2.4 GHz direct sequence spread spectrum, IEEE 802.15.4 radio.
6305-1011	G-LINK-10G-2400-SKA	G-LINK-10G-2400-SKA, G-LINK starter kit includes one G-LINK wireless triaxial accelerometer node with ± 10 g range, one analog/digital output base station with power supply, charger and Agile-Link software. Operates on 2.4 GHz direct sequence spread spectrum, IEEE 802.15.4 radio.
6305-1041	G-LINK-10G-2400-SK1	G-LINK-10G-2400-SK1, G-LINK starter kit includes one G-LINK wireless triaxial accelerometer nodes with ± 10 g range, one USB base station, charger and Agile-Link software. Operates on 2.4 GHz direct sequence spread spectrum, IEEE 802.15.4 radio.
6305-1042	G-LINK-10G-2400-SK2	G-LINK-10G-2400-SK2, G-LINK starter kit includes two G-LINK wireless triaxial accelerometer nodes with ± 10 g range, one USB base station, charger and Agile-Link software. Operates on 2.4 GHz direct sequence spread spectrum, IEEE 802.15.4 radio.
6306-0100	G-LINK-IP65-ENCL	G-LINK-IP65-ENCL, IP65/NEMA4 rated high strength fiberglass enclosure, with 9V battery clip. Dimensions: 2.5" x 4.5" x 3".

Table 3

6306-0200	G-LINK-IP65-XL-ENCL	G-LINK-IP65-XL-ENCL, IP65/NEMA4 rated high strength fiberglass enclosure, with non-rechargeable 3.6V Lithium D cell battery. Dimensions: 2.94" x 2.18" x 6.3".
6306-0300	G-LINK-IP65-XXL-ENCL	G-LINK-IP65-XXL-ENCL, IP65/NEMA4 rated high strength fiberglass enclosure, with 3 parallel non-rechargeable 3.6V Lithium D cell batteries. Dimensions: 2.2" x 4.4" x 6.8".
6302-3000	HIGH-G-OPTION	HIGH-G-OPTION, modify wireless nodes to operate in excess of 550 g. Install high g crystals, pot entire assembly and install internal antenna.
6302-4000	IP65-MAG	IP65-MAG, pair of magnetic mounting strips for use with the wireless IP65 enclosures.

Table 3 con't

Common Terms

These terms are in common use throughout the manual:

- **Address:** Each node has a unique address from 1 to 65534 which identifies the node to the base station and software.
- **Base Station:** The transceiver base station attaches to your host computer and provides communication between the software and the node(s).
- **Bits:** The digital equivalent of voltage on the node. The 12-bit A/D converter returns bit values ranging from 0-4096 bits.
- **Broadcast:** Any of a number of commands (trigger, sleep, erase, etc.) transmitted at the same instant to multiple nodes.
- **Browse Triggers:** The software action whereby one can display and analyze the datalogging sessions in CSV format.
- **Channel Actions:** Coefficients contained on-board the node to instruct the host software to scale engineering units.
- **Configuration:** A general term applied to the node indicating the streaming or datalogging environment. The number of active channels, sampling rate, offset, hardware gain, etc. are all components of a node's configuration.
- **Continuous:** A term used to describe a sampling session (datalogging, streaming, LDC, HSS) where the time length of the session is undefined.
- **CSV:** Comma Separated Values; a data file which has its data separated by commas; will import into most spreadsheet and analysis programs.
- **Cycle Power:** A command transmitted to the node to re-boot the node.
- **Datalogging:** Datalogging is a node action whereby all active channels (and the sensors attached to them) are sampled and the data acquired is written to non-volatile memory on-board the node. The data is not transmitted to the base station and software during datalogging. Datalogging can either be finite (have a user defined start and end time) or continuous (continue until all datalogging memory is consumed).
- **Download:** Download is the node action whereby the node transmits all of its datalogging data to the base station and software for file saving.
- **Erase:** A command transmitted to the node to erase all datalogging sessions.
- **Finite:** A term used to describe a sampling session (datalogging, streaming, LDC, HSS) where the time length of the session is defined.
- **High Speed Streaming: High Speed Streaming (HSS)** is a node action whereby all active channels (and the sensors attached to them) are sampled and the data acquired is transmitted to the base station and software. The data is not written to non-volatile memory during HSS. HSS can either be finite (have a user defined start and end time) or continuous (continue until the power is cycled on the node). It differs from Streaming in that it offers faster data rates.
- **Low Duty Cycle:** Low Duty Cycle (LDC) is a node action whereby all active channels (and the sensors attached to them) are sampled and the data acquired is "blipped" to the base station and software. The data is not written to non-volatile

memory during LDC. LDC can either be finite (have a user defined start and end time) or continuous (continue until the power is cycled on the node).

- **Node:** The node is the wireless transceiver that carries the sensors and provides communication with the base station. The G-Link®, V-Link®, SG-Link® and TC-Link® are all nodes.
- **Ping:** A byte is transmitted by the base station to a particular node and the node responds by echoing the byte indicating communication exists between the base station and the node.
- **Plugins:** Software ‘wizards’ which aid in the configuration of the node’s sensors.
- **Range Test:** A continuous string of pings used to validate communication between the base station and the node over distance and obstruction.
- **Read/write EEPROM:** Commands transmitted to the node to read or write parameters stored in the node’s operating system.
- **SEDT:** Sensor Event Driven Trigger is a method whereby a ceiling or floor output threshold can be set in the node to automatically trigger datalogging.
- **Sleep:** A command to set a node into low power mode, useful for extending battery life.
- **Streaming:** Streaming is a node action whereby all active channels (and the sensors attached to them) are sampled and the data acquired is transmitted to the base station and software. The data is not written to non-volatile memory during streaming. Streaming can either be finite (have a user defined start and end time) or continuous (continue until the power is cycled on the node).
- **Sweep Rate:** A node setting which determines the number of times all active channels are sampled during a finite sampling session.
- **Trigger:** A command transmitted to the node to begin a datalogging session.
- **Wake:** A command transmitted to the node to recover a node in sleep configuration.

Operation

Let's discuss the operation of the G-Link® and base station in conjunction with the Agile-Link™ host software.

The G-Link® has 3 accelerometers mounted on each of its 3 axes (X, Y and Z). The G-Link® samples these accelerometers using four different selectable modes. The data is either stored temporarily on-board the G-Link® or immediately transmitted to a base station, depending on the sampling method. The base station is read by the host software as data is received, and the host software displays and/or saves the data to file.

The 3 accelerometer sensors and the temperature sensor are each assigned to a separate channel: channel 1 = X accelerometer, channel 2 = Y accelerometer, channel 3 = Z accelerometer, and channel 4 = temperature sensor. Each sensor is excited with 3 volts and all four sensors are captured by the microprocessor through a 12 bit A-to-D converter. The firmware in the microprocessor processes the digital sampling into raw data and, depending on the sampling method selected, either writes the data as it is captured to the flash memory or sends the data through the serial communication interface to the radio. The radio in turn transmits the data to any listening base station.

Please refer to the *System Block Diagram* section of this manual for a visual representation of the G-Link®, base station and host software operation.

In the **DATALOGGING** sampling method, the G-Link® may be configured to sample data as fast as 2048 samples per channel per second to as slow as 32 samples per channel per second. Datalogging can be finite or continuous. In finite datalogging, a sampling duration is set and the datalogging session will last the duration once initiated. The data will be written to the memory on-board the G-Link® during the session. In continuous datalogging, the one session will last until the memory is full. Multiple finite datalogging sessions may be conducted with the G-Link® before its memory is full. No data is transmitted over the air to the base station during datalogging. When datalogging is completed (one or more sessions), the software provides for the data to be downloaded from the G-Link® through the base station. The software parses the data into CSV formatted files for further analysis.

In the **STREAMING** sampling method, the G-Link® sampling rate is directly dependent on the number of sensor channels which are active. With 1 channel active, the channel will be sampled at a rate of 736 samples per second; with 4 channels active, each channel will be sampled at a rate of 565 samples per second. Streaming duration can be finite or continuous. In finite streaming, a sampling duration is set and the streaming session will last the duration once initiated. In continuous streaming, the streaming session will last until the host software stops the session or the power is cycled on the G-Link®. The data is transmitted over the air to the base station during streaming; no data is written to the on-board memory during the session. During streaming, the software receives the data from the base station, parses, caches and displays the data and provides for the data to be saved into CSV formatted files for further analysis. Please note that the Analog base

station will support streaming through its analog backplane; see the *Base Station* manual for details.

In the **LOW DATA DUTY** sampling method, the G-Link® may be configured to sample data as fast as 500 samples per channel per second to as slow as 1 sample per channel per hour. Low Duty Cycle can be finite or continuous. In finite low duty cycle, a sampling duration is set and the low duty cycle session will last the duration once initiated. In continuous low duty cycle, the low duty cycle session will last until the host software stops the session or the power is cycled on the G-Link®. The data is transmitted over the air to the base station during low duty cycle; no data is written to the on-board memory during the session. During low duty cycle, the software receives the data from the base station, parses, caches and displays the data and provides for the data to be saved into CSV formatted files for further analysis. Please note that the Analog base station will support streaming through its analog backplane; see the *Base Station* manual for details.

In the **HIGH SPEED STREAMING** sampling method, the G-Link® sampling rate is directly dependent on the number of sensor channels which are active. With 1 channel active, the channel will be sampled at the rate of 4000 samples per second; with 4 channels active, each channel will be sampled at the rate of 1000 samples per second. High Speed Streaming can be finite or continuous. In finite high speed streaming, a sampling duration is set and the high speed streaming session will last the duration once initiated. In continuous high speed streaming, the high speed streaming session will last until the host software stops the session or the power is cycled on the G-Link®. The data is transmitted over the air to the base station during high speed streaming; no data is written to the on-board memory during the session. During high speed streaming, the software receives the data from the base station, parses, caches and displays the data and provides for the data to be saved into CSV formatted files for further analysis.

Please review the *Sampling Rates* section of this manual for datalogging, streaming, low duty cycle and high speed streaming sampling rate details.

Multiple G-Link®'s (nodes) and/or base stations may be operated at the same time depending on the sampling method in use.

In the **Datalogging** sampling method, you may trigger a datalogging session on any number of G-Link®s at the same instant by broadcasting a datalogging command from one base station to all the nodes. In this case, all nodes and the base station operate on the same frequency. All nodes would receive the command and independently perform their datalogging session. Each node would be downloaded separately.

In the **Streaming** sampling method, you may trigger a streaming session on up to 16 G-Link®s at the same instant by broadcasting a streaming command from multiple base stations to each base station's corresponding node. In this case, a base station would be deployed for each node and each pair would be set to a separate frequency so as not to conflict with other pairs. All nodes would receive the command and independently stream their data to the paired base station. Agile-Link™ software is capable of handling

up to 4 node/base station pairs; application developers would be able to operate up to 16 pairs in this fashion. This limit of 16 results from the number of available frequencies within the band spectrum of the G-Link® radio.

In the **Low Duty Cycle** sampling method, multiple G-Link®s can share the same frequency since each node is not transmitting continuously. You may start a low duty cycle session on any number of G-Link®s at the same instant by broadcasting a low duty cycle command from one base station to all the nodes. All nodes receive the command and independently begin transmitting their low duty cycle data. The base station receives the data from all the nodes and passes it on to the host software.

It should be noted here that when using multiple nodes with one base station in low duty cycle mode, the total number of nodes that can be simultaneously sampled is dependent on the number of active channels and the sampling rate. As the number of active channels increases and/or sampling rates increase, the total number of nodes that can be sampled falls. Likewise, as the number of active channels decreases and/or sampling rates decrease, the total number of nodes that can be sampled increases.

In the **High Speed Streaming** sampling method, you may trigger a high speed streaming session on up to 16 G-Link®s at the same instant by broadcasting a high speed streaming command from multiple base stations to each base station's corresponding node. In this case, a base station would be deployed for each node and each pair would be set to a separate frequency so as not to conflict with other pairs. All nodes would receive the command and independently stream their data to the paired base station. MicroStrain's High Speed Streaming software is capable of handling only 1 node/base station pair; application developers would be able to operate up to 16 pairs in this fashion. This limit of 16 results from the number of available frequencies within the band frequency of the G-Link® radio.

The analog base station has an additional feature relating to sampling methods. It normally is configured to support up to 8 channels of data from a single node. However, it may be configured to support up to 8 nodes, that is to say, it may be configured to handle one channel of data from up to 8 individual G-Link®s. Please refer to the Agile-Link™ Base Station manual which is contained on the Agile-Link™ CD and on our web site for detailed instructions on its use with G-Link®.

The G-Link® has an additional datalogging feature which we describe as **Sensor Event Driven Trigger (SEDT)**. In SEDT, the G-Link® may be configured to commence datalogging automatically each time a "ceiling" or "floor" sensor output is met. For example, you may set the G-Link® so that a datalogging session is triggered whenever channel 3 (the Z axis accelerometer) exceeds (goes through the ceiling of) 1G. The session will begin automatically, run its finite duration and stop. With the next 1G ceiling event, the G-Link® would again run a datalogging session automatically without manual intervention.

When the G-Link® is not sampling, it can be in one of two states: Sleep or idle. In Sleep mode, the G-Link®, on a settable interval (by default 5 seconds), momentarily awakens and listens for any commands. If a command is heard, it wakes and responds to the command; if no command is heard, it goes back to sleep. This sleep function is used to conserve battery power. In idle mode, the G-Link® is awake and listening for commands from a base station.

Several configuration/operational/test functions exist for the G-Link®; some of the more often used functions are listed below.

- A **Verify** will test whether the base station and software are communicating successfully.
- A **Ping** will test whether a single byte transmission from the base station to the node is successful.
- A **Range Test** will test whether communication is being maintained over a period of time between the base station and the node.
- A **Cycle Power** will have the effect of manually cycling the power on the node.
- **Node Discovery** allows the base station to detect any node on any frequency as it is powered on.
- **Load Node Information** reads and displays the model, serial number, firmware version and other statistics of the node.
- **Frequency** allows reading and setting of the channel on which the node is operating.
- **Read/Write EEPROM** allows direct reading and setting of parameters maintained in EEPROM.

Please see the Agile-Link™ software manual for more information on software accessible features of the G-Link®.

Base Stations

The G-Link® is designed to operate with any of the Agile-Link™ wireless family base stations. These base stations include the USB base station, the Analog base station and the Serial base station. Please refer to the Agile-Link™ Base Station manual which is contained on the Agile-Link™ CD and on our web site for detailed instructions on their use with G-Link®.

USB Base Station

The MicroStrain USB base station is a transceiver which provides a communication link between a host computer and the Agile-Link™ family of wireless nodes including V-Link®, SG-Link®, G-Link® and TC-Link®. The USB base station employs a 2.4 GHz radio with 16 selectable channels to communicate with the remote nodes. The USB base station is connected to a host computer via a USB connection and is operated with MicroStrain's Agile-Link™ software. The USB base station, under



instruction from the software, wirelessly communicates with the Agile-Link™ nodes, alternately sending commands and configurations, and receiving responses and data. The USB base station sends all of the commands available to the nodes including ping, datalog, stream data, erase, read and write EEPROM, etc. The USB base station in turn receives acknowledging responses from the nodes and passes datalogging downloads, streaming data, high speed streaming data and low duty cycle data to the host computer. The USB base station is capable of maintaining communications with multiple nodes. Its broadcast mode allows the simultaneous issuance of several commands to multiple nodes.

Analog Base Station

The MicroStrain Analog base station is a transceiver which provides a communication link between a host computer and the Agile-Link™ family of wireless nodes including V-Link®, SG-Link®, G-Link® and TC-Link®. The Analog base station employs a 2.4 GHz radio with 16 selectable channels to communicate with the remote nodes. The Analog base station is connected to a host computer via a USB or an RS-232 connection and is operated with MicroStrain's Agile-Link™ software. The



Analog base station, under instruction from the software, wirelessly communicates with the Agile-Link™ nodes, alternately sending commands and configurations, and receiving responses and data. The Analog base station sends all of the commands available to the nodes including ping, datalog, stream data, erase, read and write EEPROM, etc. The

Analog base station in turn receives acknowledging responses from the nodes and passes datalogging downloads, streaming data, high speed streaming data and low duty cycle data to the host computer. The Analog base station is capable of maintaining communications with multiple nodes. Its broadcast mode allows the simultaneous issuance of several commands to multiple nodes. The Analog base station also features direct analog output of wireless node data on its back panel and is deployable in a stand-alone condition without need of host computer.

Serial Base Station

The MicroStrain Serial base station is a transceiver which provides a communication link between a host computer and the Agile-Link™ family of wireless nodes including V-Link®, SG-Link®, G-Link® and TC-Link®. The Serial base station employs a 2.4 GHz radio with 16 selectable channels to communicate with the remote nodes. The Serial base station is connected to a host computer via an RS-232 connection and is operated with MicroStrain's Agile-Link™ software. The Serial base station, under



instruction from the software, wirelessly communicates with the Agile-Link™ nodes, alternately sending commands and configurations, and receiving responses and data. The Serial base station sends all of the commands available to the nodes including ping, datalog, stream data, erase, read and write EEPROM, etc. The Serial base station in turn receives acknowledging responses from the nodes and passes datalogging downloads, streaming data, high speed streaming data and low duty cycle data to the host computer. The Serial base station is capable of maintaining communications with multiple nodes. Its broadcast mode allows the simultaneous issuance of several commands to multiple nodes.

Accelerometers

General Information

- The G-Link® is available in either +/- 2G or +/- 10G accelerometer ranges.
- Both G-Link® models integrate two orthogonally mounted, dual-axis MEMS accelerometers from Analog Devices.
- Specifications for the +/- 2G (Model ADXL202) may be found at: <http://www.analog.com/en/prod/0%2C2877%2CADXL202%2C00.html>
- Specifications for the +/- 10G (Model ADXL210) may be found at: <http://www.analog.com/en/prod/0%2C2877%2CADXL210%2C00.html>
- Triaxial accelerometer output is presented on G-Link® channels 1, 2 and 3, being X, Y and Z for orientation purposes.

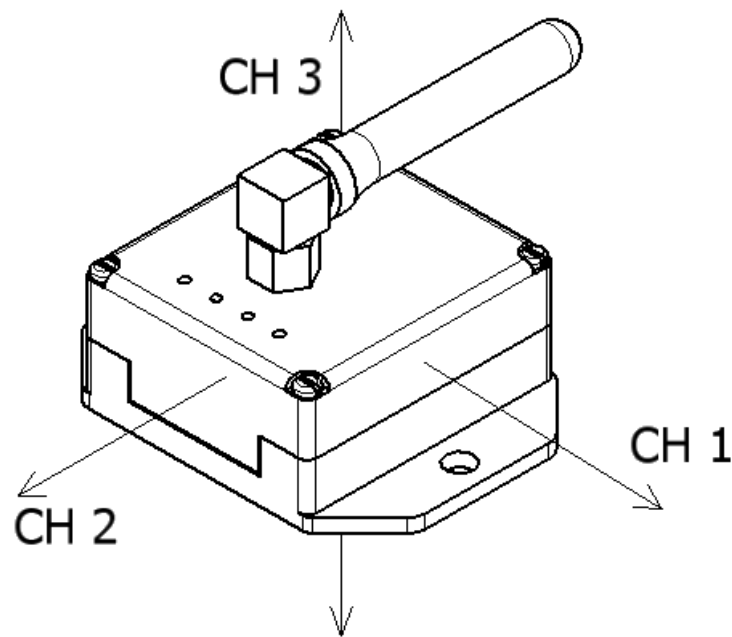

Figure 2

Conversion to Physical Units

The G-Link® is shipped with factory calibration coefficients (residing in non-volatile EEPROM) for converting the raw A/D converter data (bits) to g's. Each accelerometer is calibrated by rotation through Earth's gravity field, providing a +1g and -1g (2 points) reference. In Agile-Link™ software, these may be used by employing the Channel Actions function.

Low Pass Filter/Anti-aliasing Filter

As shown in the *System Block Diagram* elsewhere in this manual, the G-Link® uses a 0.022 uF capacitor for the low pass filter on the output of the ADXL202/ADXL 210 accelerometers. This translates to a -3dB down point at approximately 250 Hz.

Temperature Sensor

General Information

- The G-Link® has an on-board, solid state temperature sensor mounted on the surface of the circuit board.
- Specifications for this National Semiconductor Model LM60 sensor may be found at: <http://www.national.com/mpf/LM/LM60.html>
- The temperature sensor output is presented on channel 4 of the G-Link®.
- The temperature sensor has a measurement range of -25°C to +70°C range, typical accuracy $\pm 0.5^\circ\text{C}$ (@25°).

Conversion to Physical Units

The G-Link® temperature sensor outputs 6.25 mV/°C. The Agile-Link™ software uses and any other application should use this formula to calculate temperature:

$$Temp [^\circ\text{C}] = \frac{\left\{ BitsOut \times \left(\frac{3000 [mV]}{4096 [Bits]} \right) \right\} - 424 [mV]}{6.25 \left[\frac{mV}{^\circ\text{C}} \right]}$$

LEDs

The G-Link® has four LED indicators on its faceplate. The LEDs signal the various operating states of the G-Link® to the user.

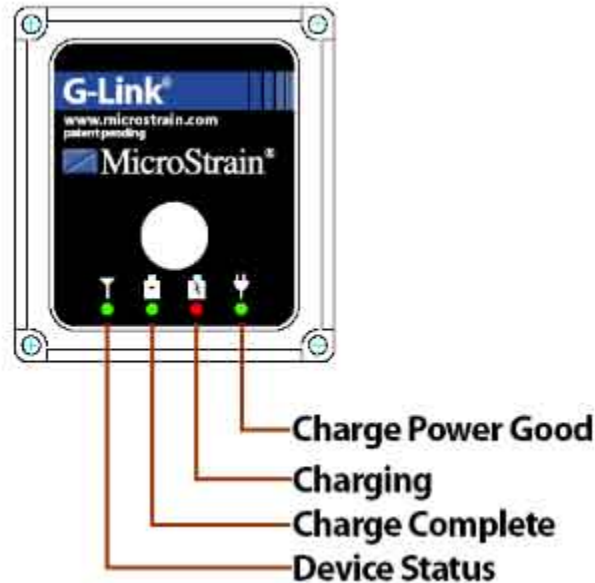

Figure 3

Charge Power Good LED

The **green** Charge Power Good LED illuminates when the external power supply is connected and proper voltage is being supplied to the charging circuit, and continues to illuminate while the internal battery charging circuit is active.

Charging LED

The **red** Charging LED illuminates when the external power supply is connected and continues to illuminate while the internal battery charging circuit is active. When the internal battery is fully charged, the LED turns off in favor of the **green** Charge Complete LED. The **red** Charging LED will also turn off if the external power supply is removed prior to full charge.

Charge Complete LED

The **green** Charge Complete LED will illuminate only during a charging session and only when the battery is fully charged. The **green** Charge Complete LED will turn off if the external power supply is removed.

Device Status LED

The green Device Status LED indicates the current state of the G-Link®. When the G-Link® is switched on, the green Device Status LED will rapidly flash several times and in a moment, begin ‘throbbing’ on and off every 1 second. The rapid flashes indicate a successful boot-up. The ‘throbbing’ indicates that the G-Link® is active and in an idle state.

The Device Status LED has several states during **normal** operation:

State	LED appearance
Booting up	Rapidly flashes 10 times when power is applied/recycled
Active and idle	‘Throbbing’ on and off every 1 second
Datalogging	Illuminates continuously
Streaming	Illuminates continuously
High Speed Streaming	Illuminates continuously
Low Duty Cycle	Blips on/off based on sampling rate
Ping	Blips on/off once for each ping
Range Test	Blips on/off at high rate giving appearance of continuous illumination
Read/Write EEPROM	Rapidly flashes several times
Sleep	Faint blip on/off based on Check Radio Interval

Table 4

The Device Status LED has several states during **error** operation:

State	LED appearance
Radio error	Blinks slowly 4 times on boot-up
On-board 2MB flash memory error	Blinks slowly 5 times on boot-up

Table 4A

Radio and Antenna

The G-Link® and its base station employ a 2.4 GHz IEEE 802.15.4 compliant radio transceiver for wireless communication. The radio is designed to comply with ETSI EN 300 328, EN 300 440 class 2, FCC CFR-47 part 15 and ARIB STD-T66. For additional information on regulatory approvals, please FCC and IC Certification sections of this manual.

The G-Link® has a 2.4 GHz omni-directional, right-angle, ¼ wave antenna extending from the faceplate of the G-Link®. The antenna is mounted to a male reverse polarity SMA connector (RP-SMA) extending through the enclosure from the circuit board assembly. Antenna specifications may be found at:

http://www.antennafactor.com/documents/ANT-2.4-CW-RCS_Data_Sheet.pdf

The stated range for the G-Link® is up to 2000 meters line-of-sight from its base station when in extended range mode and 70 meters line-of-sight when in standard range mode.

Node Addressing

Each node has a unique address from 1 to 65534 which identifies the node to the base station and software. Typically, the factory assigns the last 4 digits of the node's serial number as the address, and changes to this address are not recommended except under special circumstances.

Address 65535 is a specialized broadcast node address. For example, if several nodes hear a command for node 65535 to start datalogging, they will all initiate datalogging simultaneously. It is extremely important that no particular node be assigned the 65535 broadcast address.

Note: The Streaming and High Speed Streaming commands in Agile-Link™ software can not use the broadcast 65535 address.

Sample Duration Calculations

Datalogging, streaming, low duty cycle and high speed streaming sampling sessions can all be set to last a finite duration, a finite amount of time. Finite sample duration is a value ranging from 100 to 65500, in increments of 100.

A datalogging example: We set the number of active channels to 3. We set the sample rate to 32. We set the sampling duration to 1000. We trigger the session. We download the session. We find that we have 1000 rows of data, with each row containing 3 channels of sensor data. We see that the session lasted ~31.25 seconds.

Another datalogging example: We set the number of active channels to 1. We set the sample rate to 1024. We set the sampling duration to 10000. We trigger the session. We download the session. We find that we have 10000 rows of data, with each row containing 1 channel of sensor data. We see that the session lasted ~9.77 seconds.

From this it becomes clear how the sampling duration can be thought of as a time setting:

- In our first example, we can divide a sampling duration of 1000 by a sample rate of 32 to equal ~31.25 seconds.
- In our second example, we can divide a sampling duration of 10000 by a sample rate of 1024 to equal ~9.77 seconds.

A streaming example: We set the number of active channels to 3. We can't set the sample rate because that is fixed in hardware and we know it will be 617. We set the sampling duration to 10000. We start the session. We save the session. We find that we have 10000 rows of data, with each row containing 3 channels of sensor data. We see that the session lasted ~16.21 seconds. As before, 10000 sampling duration divided by 617 sample rate = ~16.21 seconds.

A low duty cycle example: We set the number of active channels to 3. We set the sample rate to 1. We set the sampling duration to 100 (100 is the minimum setting in Agile-Link™ software). We start the session. We save the session. We find that we have 100 rows of data, with each row containing 3 channels of sensor data. We see that the session lasted ~100 seconds. As before, 100 sampling duration divided by 1 sample rate = ~100 seconds.

A high speed streaming example: We set the number of active channels to 4. We can't set the sample rate because that is fixed in hardware and we know it will be 1000. We set the sampling duration to 10000. We start the session. We save the session. We find that we have 10000 rows of data, with each row containing 4 channels of sensor data. We see that the session lasted ~10 seconds. As before, 10000 sampling duration divided by 1000 sample rate = ~10 seconds.

Time Stamping

The G-Link® node and Agile-Link™ software handle time stamping of datalogging, streaming, low duty cycle and high speed streaming data in different ways. The table below describes the various methods:

Sampling Method	Time Stamp	Source	Clock Type	Stability
Datalogging	Omitted to maximize data rate	Node	Crystal	+/-25ppm
Streaming	Omitted to maximize data rate	Node	Crystal	+/-25ppm
LDC \leq 1 Hz ⁽¹⁾	16-bit counter	Node	RC	+/-10%
	Absolute time stamp	PC	Windows OS	---
LDC $>$ 1 Hz	16-bit counter	Node	Crystal	+/-25ppm
High Speed Streaming	16-bit counter	Node	Crystal	+/-25ppm

Table 5

Notes:

(1) 16-bit counter and absolute time stamp are both applied.

Power

The G-Link® is normally powered by its internal rechargeable lithium polymer battery and may also be powered by an external source.

On/Off Switch

The G-Link® has a 2 position on-and-off slide switch on its sidewall next to the power barrel connector. **OFF** is towards the barrel connector; **ON** is away from the barrel connector.



Figure 4

Internal Battery

The G-Link® contains an internal rechargeable Ultralife® brand 3.7 volt Lithium Ion battery UBC005 <http://www.ultralifebatteries.com/datasheet.php?ID=UBC005>.

The G-Link® internal battery has a manufacturer stated nominal capacity of 200 mAh @ C/5 Rate @ 23° C.

The G-Link® internal battery has a manufacturer stated recharge cycle life of >300 cycles @ C/5 to 80% of initial capacity. A rule-of-thumb would be to expect at least 300 recharges (from fully depleted to full charge) before discharge capacity begins to drop.

The internal battery should only be charged with the Phihong brand external power supply Model PSA05R-090 <http://www.phihong.com/assets/pdf/PSA05R.pdf> provided in the G-Link® starter kit. The power supply is a ‘switching’ supply and may receive an input from 100 to 240 Volts AC. It outputs +9 Volts DC. A set of 4 plug adapters are provided to accommodate most countries’ electrical services.

The G-Link® should be fully charged before each use. Charging may take up to several hours depending on battery depletion.

Charging procedure:

- Turn off the G-Link® On/Off Switch.
- Insert external power supply male connector into the G-Link® barrel connector.
- Insert power supply into wall or other electrical service.
- Observe that **both** the green Charge Power Good and red Charging LED illuminate. If only the green Charge Power Good illuminates, remove the external

power supply male connector and re-insert it into the G-Link® barrel connector until the red Charging LED illuminates. Please see the *LEDs* section of this manual for more details.

- Charging has completed when you observe that the green Charge Power Good remains illuminated, the red Charging LED turns off, and the green Charge Complete LED illuminates.
- Remove external power supply male connector.
- Turn on the G-Link® On/Off Switch.
- **Note:** The G-Link® should normally be operated with the external power supply disconnected and therefore not charging the battery.

Here are some example battery life calculations:

- Streaming consumes ~25 mA. If the G-Link® battery capacity is 200 mAh , the device will stream for ~8 hours before re-charging is required.
- Datalogging consumes ~25 mA. If the G-Link® battery capacity is 200 mAh , the device will datalog for ~8 hours before re-charging is required.
- Sleep mode consumes ~0.5 mA. If the G-Link® battery capacity is 200 mAh , the device will sleep for ~400 hours before re-charging is required.

Bypassing the Internal Battery

The G-Link® may be directly powered by external batteries, external regulated power supply or other external source. The source should deliver stable voltage, must range between 3.2 to 9.0 volts DC, and must be capable of sourcing at least 50 mA. The power must be applied through the external power supply barrel connector on the side wall of the G-Link®. Polarity must be observed: the center post is + (positive) and the outside barrel is ground.

There is an internal 2-pole switch on the back of the G-Link® circuit board that must be switched to the battery bypass position. It is accessed through a small slot on the enclosure. The figure below shows the Default position for internal battery and the Bypass position for external power source.

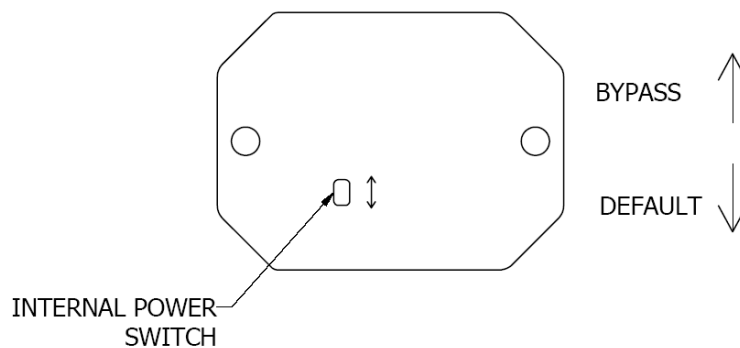

Figure 5
(G-Link® Rev I forward)

Power Profile

Power consumption on the G-Link® is influenced by a wide range of variables including operating mode, sampling rate and number of active channels. A current power profile which outlines power consumption for the matrix of operating states is available at:

http://www.microstrain.com/pdf/G-Link_PowerProfile_node_FW_4_98.pdf

Standard Enclosure

The G-Link® standard enclosure is flame retardant ABS plastic. It is a 2 part assembly with base and removable cover. It is custom manufactured for MicroStrain. Please see the *Mechanical Drawings* section of this manual for dimensions.



Figure 6

Optional Enclosures

The G-Link® is optionally available installed within IP65/NEMA 4 enclosures which provide environmental protection and/or larger battery capacity.

IP65 standard: Provides for 1) protection against a wire touching dangerous parts and, 2) sealed against dust.

NEMA 4 standard: Computer enclosures constructed for either indoor or outdoor use to provide a degree of protection to personnel against incidental contact with the enclosed equipment; to provide a degree of protection against falling dirt, rain, sleet, snow, windblown dust, splashing water, and hose-directed water; and that will be undamaged by the external formation of ice on the enclosure.

G-LINK-IP65-ENCL

Description: IP65/NEMA4 rated high strength fiberglass enclosure, with 9V battery clip.

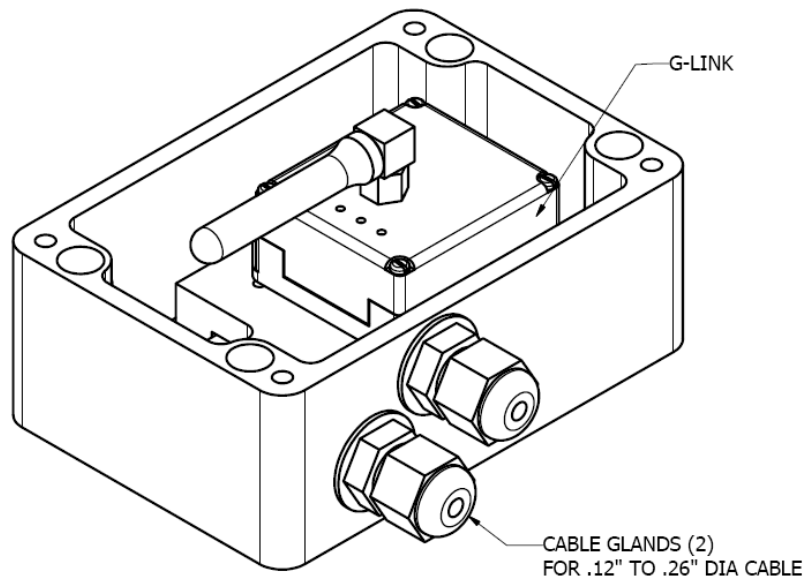

Figure 7

G-LINK-IP65-XL-ENCL

Description: IP65/NEMA4 rated high strength fiberglass enclosure, with non-rechargeable 3.6V Lithium D cell battery.

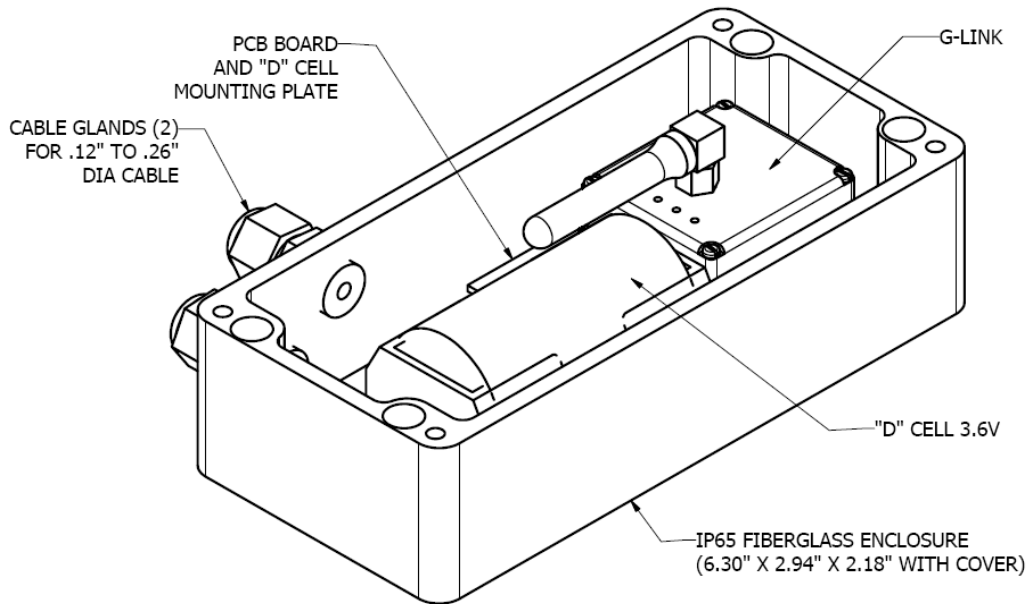

Figure 8

G-LINK-IP65-XXL-ENCL

Description: IP65/NEMA4 rated high strength fiberglass enclosure, with 3 parallel non-rechargeable 3.6V Lithium D cell batteries.

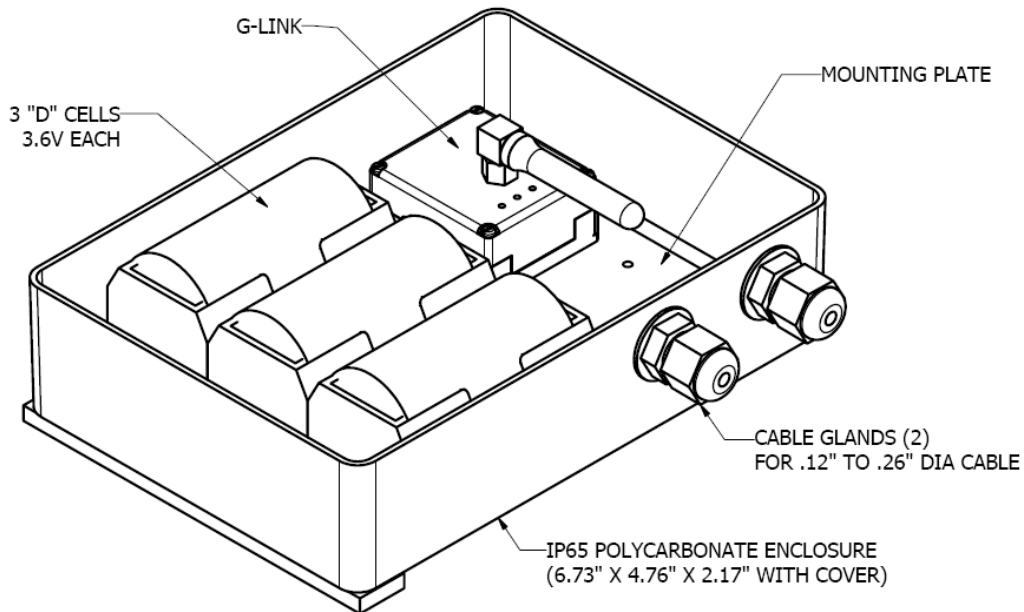

Figure 9

High G Option

The G-Link® may be optionally purchased with provisions made to withstand higher G forces. These provisions will allow the G-Link® to operate in excess of 550 g.

These provisions can include any or all of the following:

- The cavity of the standard enclosure is filled with an epoxy adhesive. The epoxy fills all voids between the enclosure and the circuit board assembly. The epoxy provides outstanding thermal shock, impact and vibration resistance.
- The radio and microprocessor crystals are replaced with higher rated crystals.
- The external mast antenna and its mount are replaced with an internal circuit board type antenna. No antenna extends from the enclosure.

Operating Temperature

The G-Link® with its standard internal battery and standard enclosure will operate between -20° C and +60° C. The battery and enclosure limit this range.

The G-Link® electronics alone will operate between -40° C and +85° C.

Extended temperature ranges can be achieved with custom batteries and enclosures. Please contact your MicroStrain Sales representative with your requirements.

Sampling Rates

As described in more detail elsewhere in this manual, the G-Link® has four sampling modes, being 1) Datalogging, 2) Streaming, 3) Low Duty Cycle and 4) High Speed Streaming. Each of these modes supports a unique set of sampling rates. In Datalogging and Low Duty Cycle modes, you may choose the sampling rate for the session. In Streaming and High Speed Streaming, the sampling rate is a function of the number of active channels being sampled and may not be set by the user.

Datalogging

The sampling rate may be set to any of the following rates:

- 32 samples per active channel per second
- 64 samples per active channel per second
- 128 samples per active channel per second
- 256 samples per active channel per second
- 512 samples per active channel per second
- 1024 samples per active channel per second
- 2048 samples per active channel per second

Streaming

The sampling rate is a function of the number of active channels:

- If 1 channel is active, the sampling rate will be 736 samples per second for the channel.
- If 2 channels are active, the sampling rate will be 679 samples per active channel per second.
- If 3 channels are active, the sampling rate will be 617 samples per active channel per second.
- If 4 channels are active, the sampling rate will be 565 samples per active channel per second.

Low Duty Cycle

The sampling rate may be set to any of the following rates:

- 500 samples per second for each active channel
- 250 samples per second for each active channel
- 100 samples per second for each active channel
- 50 samples per second for each active channel
- 25 samples per second for each active channel
- 10 samples per second for each active channel
- 5 samples per second for each active channel
- 2 samples per second for each active channel
- 1 sample per second for each active channel
- 1 sample every 2 seconds for each active channel
- 1 sample every 5 seconds for each active channel
- 1 sample every 10 seconds for each active channel

- 1 sample every 30 seconds for each active channel
- 1 sample every 60 seconds for each active channel
- 1 sample every 2 minutes for each active channel
- 1 sample every 5 minutes for each active channel
- 1 sample every 10 minutes for each active channel
- 1 sample every 30 minutes for each active channel
- 1 sample every 60 minutes for each active channel

High Speed Streaming

The sampling rate is a function of the number of active channels:

- If 1 channel is active, the sampling rate will be 4,000 samples per second for the channel.
- If 2 channels are active, the sampling rate will be 2,000 samples per active channel per second.
- If 3 channels are active, the sampling rate will be 1,330 samples per active channel per second.
- If 4 channels are active, the sampling rate will be 1,000 samples per active channel per second.

Datalogging Memory

- The G-Link® contains 2 megabytes of memory reserved for storage of datalogging.
- As a bit of background, the memory is actually organized into 8,191 ‘pages’ with each page able to hold 132 data points or a total of 8,191 pages x 132 data points = ~1,081,212 data points.
- Let’s look at some sample datalogging sessions and see how they consume memory.

Example 1

- We set the G-Link® with channels 1, 2 and 3 active, with a sampling rate of 2,048 samples per channel per second and a sweep rate of 20,000 (9.77 seconds).
- This session will produce 20,000 sweeps x 3 channels = 60,000 data points.
- This session will consume 60,000 data points / 1,081,212 data points = ~5% of the datalogging memory.
- Therefore we could run $100\% / 5\% = \sim 20$ consecutive finite datalogging sessions before we would have to download the data.

Example 2

- We set the G-Link® with channel 3 active, with a sampling rate of 512 samples per channel per second and a sweep rate of 10,000 (19.53 seconds).
- This session will produce 10,000 sweeps x 1 channels = 10,000 data points.
- This session will consume 10,000 data points / 1,081,212 data points = ~1% of the datalogging memory.
- Therefore we could run $100\% / 1\% = \sim 100$ consecutive finite datalogging sessions before we would have to download the data.

Example 3

- We set the G-Link® with channels 1, 2 and 3 active, with a sampling rate of 1,024 samples per channel per second, with continuous datalogging enabled and memory fully erased.
- This session will produce 1,024 samples per second x 3 channels = 3,072 data points per second.
- This session will last $1,081,212 \text{ data points} / 3,072 \text{ data points per second} = \sim 352$ seconds until the datalogging memory is full and the datalogging is automatically ended.

Factory Calibration

The G-Link® is calibrated at the factory using the following method:

- The G-Link® is attached to a rotary stage so that the centerline of the axis is in-line with the centerline of the particular G-Link® axis.
- The G-Link® is rotated slowly over 30 seconds using the G-Link® Calibration Wizard contained in Agile-Link™ software to capture the minimum and maximum output bits of the accelerometer.
- The minimum and maximum accelerometer bits are averaged.
- A GAIN is calculated using the formula:
 - $\text{Gain} = (\text{Average Maximum Bits} - \text{Average Minimum Bits}) / 2$
- An OFFSET is calculated using the formula:
 - $\text{Offset} = (\text{Average Maximum Bits} + \text{Average Minimum Bits}) / 2$
- This Gain and Offset is written to the non-volatile EEPROM of the G-Link®.
- This process is repeated for each of the three accelerometers, X, Y and Z.

In operation, the Agile-Link™ reads the EEPROM of the particular G-Link® and uses these calibration coefficients to produce scaled engineering units (Gs) when the G-Link® is datalogging, streaming, low duty cycling, high speed streaming and reading single sensor.

The formula embedded in the G-Link® firmware for scaling is as follows:

$$\text{Gs} = (\text{output bits} - \text{offset}) / \text{gain}$$

General Specifications

On-Board Accelerometers	Triaxial MEMS accelerometers, Analog Devices ADXL202 or ADXL210
Accelerometer Range	$\pm 2g$ or $\pm 10g$
Measurement Accuracy	10 mg
Resolution	200 $\mu g / \sqrt{Hz}$
Shock Limit	500g
Analog to Digital (A/D) Converter	Successive approximation type, 12 bit resolution
Data Storage Capacity	2 megabytes (approximately 1,000,000 data points)
Data logging mode	Log up to 1,000,000 data points (from 100 to 65,500 samples or continuous) at 32 Hz to 2048 Hz
Sensor event driven trigger	Commence datalogging when threshold exceeded
Real-time streaming mode	Transmit real time data from node to PC - rate depends on number of active channels: 1 channel - 4 KHz, 2 channels - 2 KHz, 3 channels - 1.33 KHz, 4 channels (including temp.) - 1 KHz
Low duty-cycle mode	Supports multiple nodes on single RF channel, total update bandwidth of 500 Hz divided by number of nodes
Synchronization between nodes	Datalogging 100 $\mu sec \pm 50$ ppm. LDC mode time stamped at PC
Sample rate stability	Datalogging and LDC (mode(2Hz to 500Hz) 100 $\mu sec \pm 25$ ppm (90 msec/hour) LDC mode (1 Hz to 2 samples per hour) $\pm 10\%$
Radio Frequency (RF) Transceiver Carrier	2.4 GHz direct sequence spread spectrum, license free worldwide (2.450 to 2.490 GHz) - 16 channels
RF Data Packet Standard	IEEE 802.15.4, open communication architecture
RF Programming and Downloading	8 minutes to download full memory
Range for Bi-Directional RF Link	Up to 2000 meters line-of-sight in extended range mode, 70 meters line-of-sight in standard range mode
Internal Li-Ion Battery	3.7 volt lithium ion rechargeable battery, 200 mAh capacity. Customer may supply external power from 3.2 to 9 volts
Power Consumption	Real-time streaming - 25 mA, datalogging - 25 mA, sleeping - 0.5 mA

Table 6

Operating Temperature	-20 to +60°C with standard internal battery and enclosure, extended temperature range optional with custom battery and enclosure. -40 to +85°C for electronics only
Dimensions	58 mm x 43 mm x 26 mm without antenna (board only 36 mm x 36 mm x 24 mm)
Weight	46 grams
Case	ABS plastic
Software	Agile-Link™ Windows XP Professional compatible
PC Comm	Serial port, 115.2 kBaud

Table 6 con't

Mechanical Drawings

Enclosure Dimensions

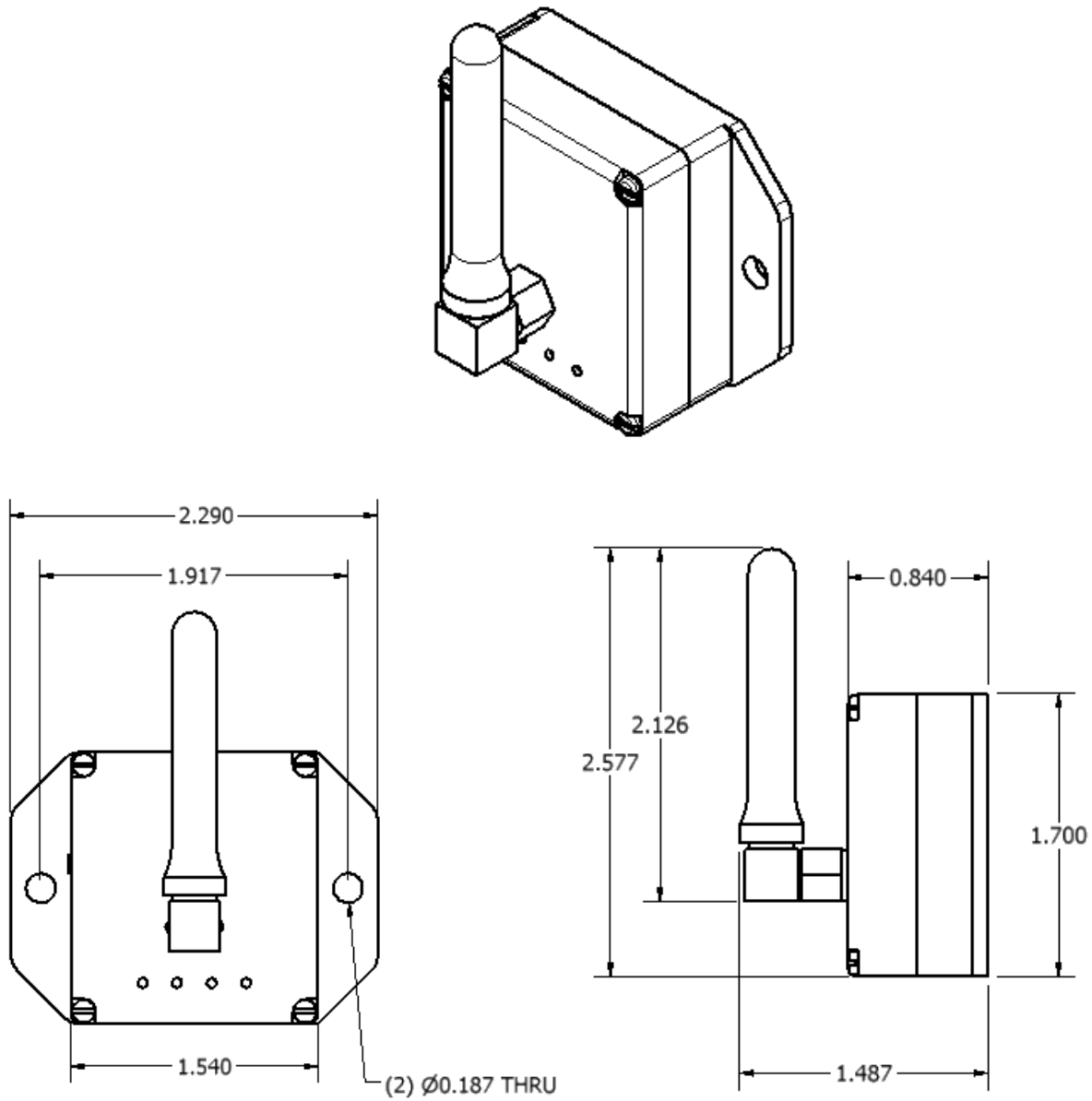

Figure 10

Circuit Board Assembly Dimensions

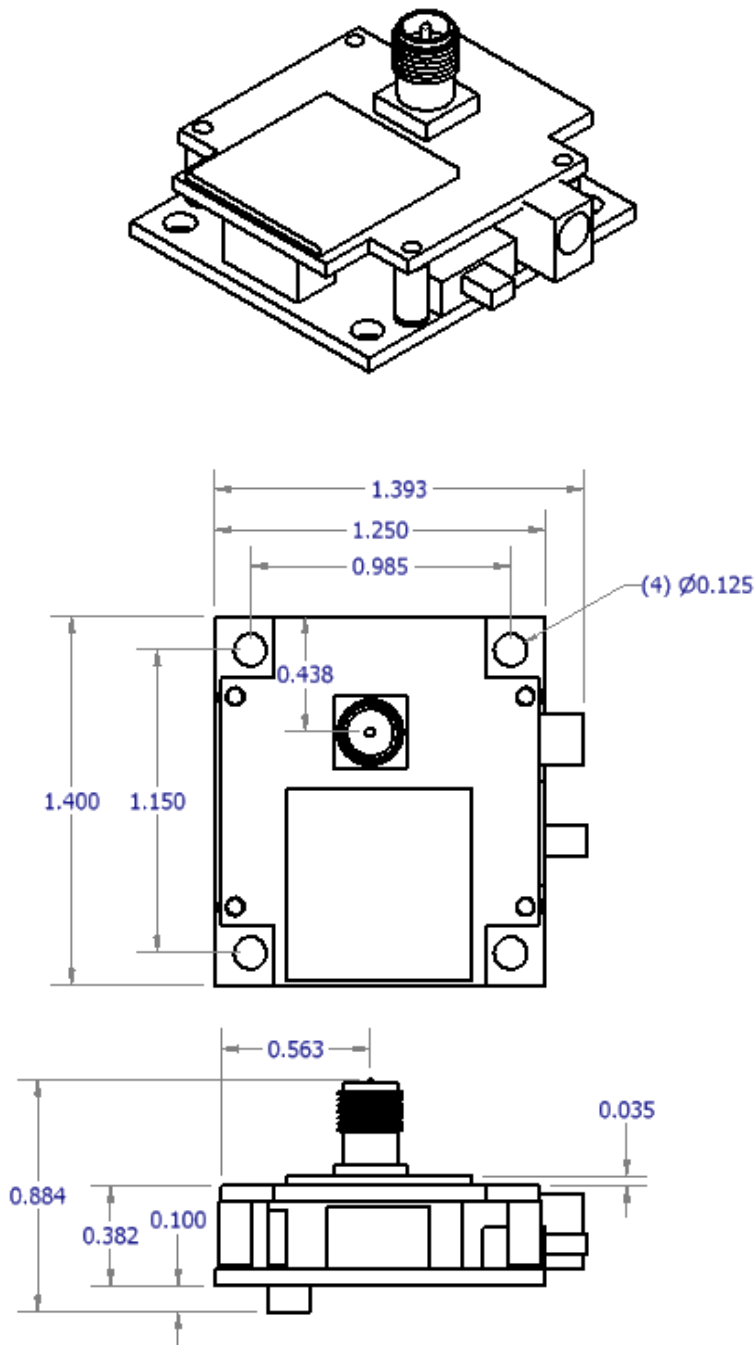

Figure 11

Measurement Axes

- Channel 1 = X axis
- Channel 2 = Y axis
- Channel 3 = Z axis

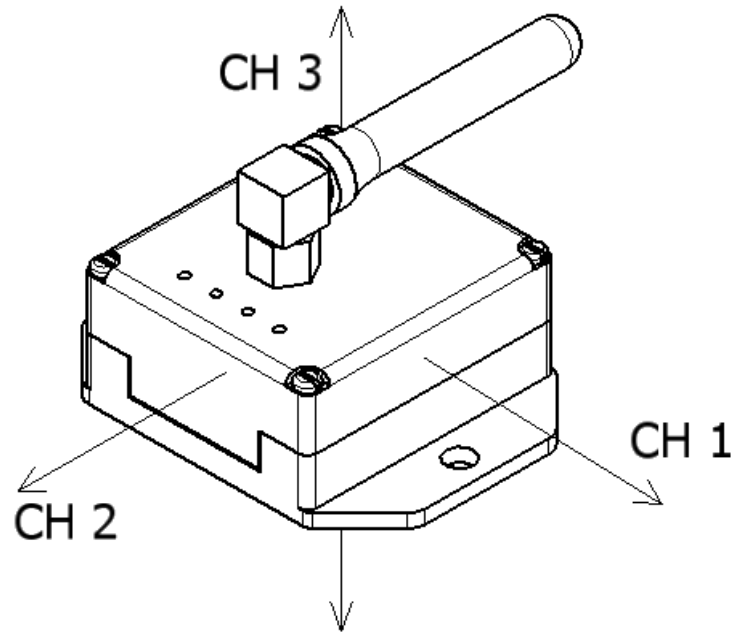

Figure 12

Calibration Axes

- Channel 1 = X axis
- Channel 2 = Y axis
- Channel 3 = Z axis

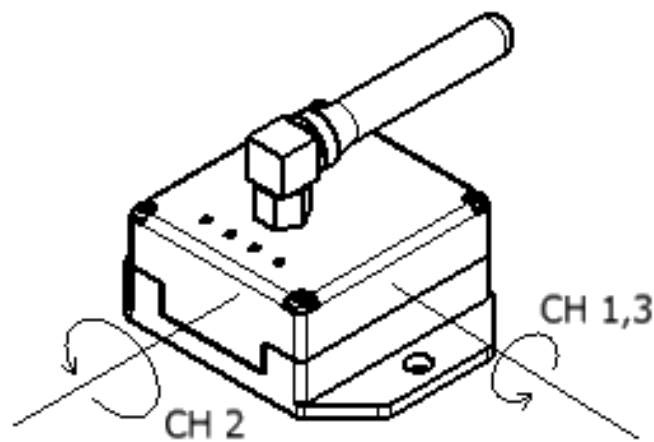

Figure 13

System Block Diagram

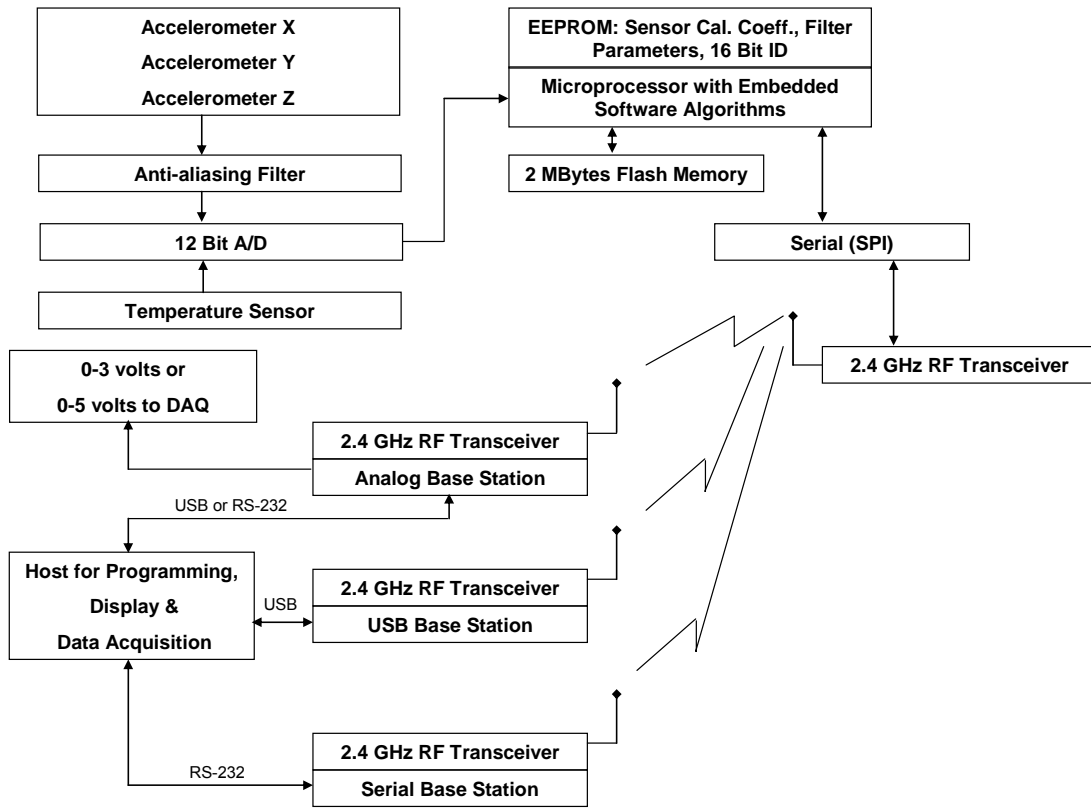

Figure 14

FCC (United States) Certification

The G-Link® complies with Part 15 of the FCC rules and regulations. Compliance with the labeling requirements, FCC notices and antenna usage guidelines is required. In order to operate under MicroStrain's FCC Certification, OEMs/integrators must comply with the following regulations:

Labeling Requirements

The G-Link® is labeled with its FCC ID number XJQMSLINK0001. If this FCC ID is not visible when the module is installed inside another device, then the outside of the device into which the module is installed must also display the following label referring to the enclosed module:

Contains FCC ID: XJQMSLINK0001

This device complies with Part 15 of the FCC Rules.

Operation is subject to the following two conditions:

- (1) this device may not cause harmful interference and**
- (2) this device must accept any interference received, including interference that may cause undesired operation.**

This equipment has been tested and found to comply with the limits for a Class B digital device, pursuant to Part 15 of the FCC Rules. These limits are designed to provide reasonable protection against harmful interference in a residential installation. This equipment generates, uses and can radiate radio frequency energy and, if not installed and used in accordance with the instructions, may cause harmful interference to radio communications. However, there is no guarantee that interference will not occur in a particular installation. If this equipment does cause harmful interference to radio or television reception, which can be determined by turning the equipment off and on, the user is encouraged to try to correct the interference by one or more of the following measures: Re-orient or relocate the receiving antenna, Increase the separation between the equipment and receiver, Connect equipment and receiver to outlets on different circuits, or Consult the dealer or an experienced radio/TV technician for help.

FCC-approved Antennas

This device has been designed and tested to operate with the antennas listed below:

- Antenna Factor (ANT-2.4-CW-RCS-SMA)

Important Notes

The G-Link® has been certified by the FCC for use with other products without any further certification (as per FCC section 2.1091). Modifications not expressly approved by MicroStrain could void the user's authority to operate the equipment.

If the G-Link® is integrated with an unintentional radiator, the OEM/integrator is responsible for testing compliance of the unintentional radiator (FCC section 15.107 & 15.109) before declaring compliance of their final product to Part 15 of the FCC Rules.

If using the G-Link® in portable applications (module antenna is less than 20cm from the human body during device operation), the integrator or end user is responsible for passing additional SAR (Specific Absorption Rate) testing based on FCC rules 2.1091 and FCC Guidelines for Human Exposure to Radio Frequency Electromagnetic Fields, OET Bulletin and Supplement C. The testing results will be submitted to the FCC for approval prior to selling the integrated unit. The required SAR testing measures emissions from the module and how they affect the person.

IC (Industry Canada) Certification

The G-Link® is labeled with its IC ID number. If this IC ID is not visible when the module is installed inside another device, then the outside of the device into which the module is installed must also display the following label referring to the enclosed module.

Contains Model: G-Link®, IC: 8505A-MSLINK0001

Integrator is responsible for its product to comply with IC ICES-003 & FCC Part 15, Sub. B - Unintentional Radiators. ICES-003 is the same as FCC Part 15 Sub. B and Industry Canada accepts FCC test report or CISPR 22 test report for compliance with ICES-003.

Transmitter Antennas

This device has been designed to operate with the antennas listed below:

- Antenna Factor (ANT-2.4-CW-RCS-SMA)

Operation is subject to the following two conditions: (1) this device may not cause interference, and (2) this device must accept any interference, including interference that may cause undesired operation of the device.

This device complies with Industry Canada licence-exempt RSS standard(s). Operation is subject to the following two conditions: (1) this device may not cause interference, and (2) this device must accept any interference, including interference that may cause undesired operation of the device.

Le présent appareil est conforme aux CNR d'Industrie Canada applicables aux appareils radio exempts de licence. L'exploitation est autorisée aux deux conditions suivantes : (1) l'appareil ne doit pas produire de brouillage, et (2) l'utilisateur de l'appareil doit accepter tout brouillage radioélectrique subi, même si le brouillage est susceptible d'en compromettre le fonctionnement.

Software

Standard Offering

All V-Link®, SG-Link® and G-Link® starter kits are shipped with a CD containing Agile-Link™ software and High Speed Streaming software. These two softwares support all capabilities of the V-Link®, SG-Link® and G-Link® including datalogging, streaming, low duty cycle, high speed streaming, configuration, data download, data file saving, real-time sensor display and other features.

System Requirements

To use the Agile-Link™ software or High Speed Streaming software, your computer must have the following minimum specifications:

- 1 GHz CPU
- Microsoft® Windows XP Professional SP2 operating system
- CD-ROM drive
- Video resolution 800 X 600
- 32MB video card
- Minimum of 256MB of memory
- Minimum of 50MB of free hard disk space for application
- Microsoft®-compatible mouse

Software Installation

- Place the Agile-Link™ CD in your CD-ROM drive and follow the on-screen instructions to install MicroStrain's Agile-Link™ software.
 - This installation places the Agile-Link™ software on your PC as well as required base station drivers. See *Appendix 2* for more details.
 - Agile-Link™ is designed for use with 2.4 GHz V-Link®, SG-Link® and G-Link®.
- The High Speed Streaming software is designed for use with the 2.4 GHz V-Link®, SG-Link® and G-Link®.
 - If you intend to use High Speed Streaming, install the software from the CD menu.
 - Refer to the *High Speed Streaming Quick Start Guide* for specialized details.
- A *Quick Start Guide* for your particular wireless node (2.4 GHz V-Link®, SG-Link®, or G-Link®) is provided on the CD to get you up and running.

Data Communications Protocol

Customers and/or developers wishing to customize the Agile-Link™ family of wireless nodes and base stations are provided with the Agile-Link™ 2.4 GHz Software Development Kit (SDK). The Agile-Link™ 2.4 GHz Software Development Kit (SDK) is designed for use with the 2.4 GHz V-Link®, SG-Link®, G-Link®, USB Base Station,

Serial Base Station and Analog Base Station. The SDK provides a complete Data Communications Protocol manual as well as code samples for C++, VB and LabVIEW.

The SDK is designed to provide the application builder with all the necessary protocol commands and responses to build robust wireless sensor applications for the Agile-Link™ wireless sensor network.

The Data Communications Protocol manual details these commands:

- Ping base station
- Read base station EEPROM
- Write base station EEPROM
- Short ping
- Read node EEPROM
- Write node EEPROM
- Download page
- Erase session data
- Trigger datalogging session
- Initiate real-time streaming
- Initiate sleep mode
- Read single sensor
- Auto-balance channel
- Long ping
- Initiate low duty cycle
- Initiate high-speed streaming
- Stop node
- ...and more

Sample applications demonstrating most protocol commands are provided with fully-commented source code and a compiled executable for Microsoft® C++ 6.0, Microsoft® C++ 7.1, Microsoft® VB 6.0, Microsoft® VB.NET 2003, Microsoft® VB.NET 2005 and LabVIEW® 7.1. The source code contains only objects native to the particular IDE with no third party controls added. The SDK is shipped on the CD with one license for use.

Support

Overview

- MicroStrain is committed to providing timely, knowledgeable, world-class support to its customers.
- We are open 24 X 7 through our web portal.
- We make every attempt to respond to your email the same business day.
- We are always available by telephone during business hours.
- We provide in-depth FAQs, manuals, quick start guides and technical notes.
- Firmware and software upgrades are made available on-line as they become available.
- Code samples in several languages are posted to aid your development.
- We support our customers as we would want to be supported.

Web

Our home page is at URL: www.microstrain.com

Our support page is at URL: http://www.microstrain.com/support_overview.aspx

Email

MicroStrain's Support Engineers make every attempt to respond to emails requesting product support within the same business day. The more detail you can provide, the quicker we will be able to understand your issues and find solutions. Data files, pictures, screen grabs, etc. are all very helpful in generating a well-thought-out solution.

Please email us at: support@microstrain.com

Telephone

MicroStrain's Support Engineers are available by phone Monday through Friday 9:00AM to 5:00PM local time. When calling MicroStrain, indicate to the receptionist that you are calling for product support and you will be promptly routed to a Support Engineer. Please have your equipment ready to test. Every attempt will be made to solve issues while you are on the line.

1.800.449.DVRT(3878) Toll Free in US
1.802.862.6629 telephone
1.802.863.4093 fax

Local time = GMT -05:00 (Eastern Time US & Canada)

SKYPE

MicroStrain's Support Engineers are available by SKYPE Monday through Friday 9:00AM to 5:00PM local. SKYPE name: **microstrain.wireless.support**

RMA

Warranty Return

As described in our 1 Year Warranty contained in the Terms and Conditions stated elsewhere in this manual, MicroStrain will incur for its own account any cost to repair/replace a MicroStrain product covered under the warranty.

Non-warranty Return

All non-warranty repairs/replacements will receive a minimum charge. The minimum charge for standard wireless, displacement and orientation products is US\$75.00. The minimum charge for non-standard or custom products is US\$150.00. If the repair/replacement charge exceeds the minimum, the minimum is folded into the total repair/replacement cost.

General Instructions

In order to return any MicroStrain product, you must contact us for a Return Merchandise Authorization number (RMA#). Call toll free (800) 449 3878 to obtain an RMA# from your MicroStrain representative.

All returned merchandise must be in the original packaging including manuals, accessories, cables, etc. with the authorization (RMA#) clearly printed on the outside of the package.

MicroStrain is not responsible for shipping costs (from and to the customer) or damage on returned items. Units to be returned should be packed carefully. Please be advised that packages sent by normal US Postal Service cannot be tracked to ensure delivery. Since MicroStrain cannot provide credit for a return without confirming its receipt, we recommend that you use a delivery service that can be tracked and or insured.

Normal turn-around for RMA items is 7 days from receipt of item by MicroStrain.

30 Day Return Policy

All stock product orders from MicroStrain may be returned within 30 days for a full refund. In order to return or exchange all or part of your order, you must contact us for a Return Merchandise Authorization number (RMA#). Call toll free (800) 449 3878 to obtain an RMA# from your MicroStrain representative.

All returned merchandise must be in the original packaging including manuals, accessories, cables, etc. with the authorization (RMA#) clearly printed on the outside of the package. Return requests must be made within 30 days of the receipt date. All free items must be returned together with purchased items in order to receive a full refund. Any shipping and/or handling charges on the original order cannot be refunded. At our discretion, we may levee a restocking fee of 15% of the cost of items returned.

MicroStrain is not responsible for shipping costs or damage on returned items. Units to be returned should be packed carefully. Please be advised that packages sent by normal US Postal Service cannot be tracked to ensure delivery. Since MicroStrain cannot provide credit for a return without confirming its receipt, we recommend that you use a delivery service that can be tracked and or insured.

A 30 Day Return must be initiated by receiving an RMA from MicroStrain.

Terms and Conditions

1. Acceptance of MicroStrain Inc's. Terms and Conditions. By placing an order with MicroStrain, Inc. ("MicroStrain"), Buyer agrees to be bound by these Terms and Conditions of Sale and Software License, if applicable. MicroStrain will not be bound by any of other terms and conditions, regardless of whether Buyer tenders terms and conditions with an order or otherwise and these terms and condition of sale prevail over any conflicting or additional terms of any quote, order, previous agreement, acknowledgment or similar communications between the parties. These Terms and Conditions supersede all prior or contemporaneous oral or written communications, proposals and representations with respect to its subject matter. The term "Products" includes collectively all physical products, Software and Embedded Software (as defined herein).

2. Pricing. All prices are quoted in US dollars, unless otherwise explicitly stated and are valid for ninety (90) days. You shall be responsible for the payment of all shipping charges, costs of freight, taxes, import fees, insurance, duties, value added taxes, and the like. Our minimum order is one hundred (\$100.00) dollars, excluding all additional charges, including shipping, taxes and the like.

3. Payment: Payment shall be made in advance, in U.S. dollars, by credit card, bank draft or letter of credit, unless otherwise agreed in writing by MicroStrain. At the sole discretion of MicroStrain, credit terms of net 30 days up to a pre-approved limit may be offered to buyer. A late payment charge of one and a half (1.5%) percent per month, or the maximum percentage rate permitted by law, if lower, shall be charged on all past due balances. Buyer agrees to pay all costs incurred by MicroStrain including, but not limited to, collection fees, court costs and attorney fees, associated with collection of past-due balance.

4. Shipping Terms. All Products delivered to you by us, shall be F.O.B. our distribution center, with risk of loss passing to you upon our delivery of the Products to a common carrier. MicroStrain will arrange payment for shipping and insurance with the carrier, but such costs are the responsibility of Buyer. Delivery times quoted are estimates only and MicroStrain shall not be liable for delays in delivery.

5. Acceptance & Returns. Shipments shall be deemed to have been accepted by the buyer upon receipt of shipment. Any discrepancy in shipment quantity must be reported within five (5) days of receipt of shipment. Buyer may return starter kits or evaluation units for any reason within thirty (30) days of the date of shipping from MicroStrain. All other returns shall be subject to a restocking fee of the greater of twenty-five (25%) percent of the invoiced amount of the returned products or one hundred (\$100.00) dollars. To qualify for a credit or refund (excluding shipping, duties or taxes), Buyer must contact MicroStrain in writing for a Return Merchandise Authorization (RMA). All Product returns shall comply with MicroStrain's Return Merchandise Authorization (RMA) policies. Custom Products and modifications of standard Products are not eligible

for return. All returns must be shipped by Buyer to MicroStrain C.I.F. our distribution center as provided in the RMA policies provided by MicroStrain.

6. Compliance with Laws, Rules & Regulations. i.) Products sold may be exported from the United States of America only in accordance with US Export Administration Regulations and diversion contrary to US law is prohibited. Buyer acknowledges that it is eligible to receive Products under US law and agrees to abide by all export or re-export restrictions. ii.) Buyer acknowledges and recognizes that Buyer shall be wholly responsible for compliance with any laws, rules and regulations pertaining to the use of any Product(s) which is incorporated into a Buyer product should such governmental approval be required for research, testing or commercial use.

7. Software License. The following terms and conditions are applicable to either MicroStrain software delivered with a Product, the software portion of the Product (“Software”) or software which is embedded in a Product (“Embedded Software”). MicroStrain grants to Buyer a non-exclusive paid-up license to use one copy of the Software on one computer, subject to the following provisions: Except as otherwise provided in this Software License, applicable copyright laws shall apply to the Software and Embedded Software. Title to the medium on which the Software is recorded or stored is transferred to Buyer, but not title to the Software or the Embedded Software. Buyer may use Software on a multi-user or network system only if either, the Software is expressly labeled to be for use on a multi-user or network system, or one copy of the Software is purchased for each node or terminal on which Software is to be used simultaneously. Buyer shall not use, make, manufacture, or reproduce copies of Software or Embedded Software. Buyer may use a copy of the Software on one computer, and is permitted to make additional copies of the Software only for backup or archival purposes. Customer is expressly prohibited from disassembling or reverse engineering the Software or Embedded Software. All copyright notices shall be retained on all authorized copies of the Software and Embedded Software.

8. Limited Warranty. MICROSTRAIN WARRANTS i) ALL PRODUCTS (EXCEPT SPARE PARTS OR REPLACEMENT PARTS AND SPARE KITS) FOR A PERIOD OF ONE (1) YEAR, AND ii) ALL SPARE PARTS OR REPLACEMENT PARTS AND SPARE KITS FOR A PERIOD OF NINETY (90) DAYS, WHICH ARE MANUFACTURED BY MICROSTRAIN SHALL BE FREE FROM MATERIAL DEFECTS IN WORKMANSHIP AND MATERIALS FROM THE DATE OF DELIVERY TO THE CUSTOMER. THIS WARRANTY EXTENDS ONLY TO THE ORIGINAL CUSTOMER OF MICROSTRAIN, AND IS EXPRESSLY IN LIEU OF ALL OTHER WARRANTIES, EXPRESS OR IMPLIED, WHETHER OF MERCHANTABILITY OR FITNESS FOR A PARTICULAR PURPOSE OR USE, AND OF ALL OTHER OBLIGATIONS AND LIABILITIES OF ANY KIND OR CHARACTER WHICH MAY OTHERWISE APPLY. EXCEPT FOR THE WARRANTY DESCRIBED HEREIN, MICROSTRAIN EXPRESSLY DISCLAIMS ALL WARRANTIES OF MERCHANTABILITY OF THE GOODS OR OF FITNESS FOR ANY PURPOSE. THERE ARE NO OTHER WARRANTIES EXPRESS OR IMPLIED EXCEPT THOSE SPECIFICALLY PROVIDED FOR HEREIN. BY

ACCEPTING THE PRODUCTS FROM MICROSTRAIN, THE BUYER ACKNOWLEDGES AND AGREES: i) THAT THE INHERENT VALUE OF THE PRODUCTS ARE UNRELATED TO THE VALUE OR COST OF ANY PROPERTY IN CONNECTION WITH WHICH THE PRODUCTS MAY BE USED AND THAT MICROSTRAIN MAKES NO WARRANTY THAT THE PRODUCTS WILL AVERT, DETECT OR PREVENT OCCURRENCES OR THE CONSEQUENCES THEREFROM WHICH THE PRODUCTS ARE DESIGNED TO DETECT OR AVERT, OR THAT THE PRODUCTS MAY NOT BE COMPROMISED, DISABLED OR CIRCUMVENTED; ii) THAT MICROSTRAIN HAS MADE NO CONTRARY REPRESENTATIONS OR WARRANTIES OF ANY KIND, EXPRESS OR IMPLIED, TO OR FOR THE BENEFIT OF CUSTOMER; and, iii) THAT ANY NUMBER OF CAUSES MAY CAUSE A “FALSE ALARM” OR “FALSE READING” FROM MICROSTRAIN’S PRODUCTS, AND THAT MICROSTRAIN DOES NOT WARRANT AGAINST SUCH FALSE RESULTS. BUYER REPRESENTS, WARRANTS AND INDEMNIFIES MICROSTRAIN FOR ANY AND ALL LIABILITY PERTAINING TO THE USE OF PRODUCTS INCORPORATED INTO OR OTHERWISE USED IN A BUYER PRODUCT.

9. Limited Software Warranty. MicroStrain warrants that, the software portion of the Product (“Software”), where applicable, will substantially conform to MicroStrain’s then current functional specifications for the Software, as set forth in the applicable documentation, from the date of original retail purchase of the Software for a period of ninety (90) days (“Software Warranty Period”), provided that the Software is properly installed on approved hardware and operated as contemplated in its documentation. MicroStrain further warrants that, during the Software Warranty Period, the magnetic media on which MicroStrain delivers the Software will be free of physical defects. MicroStrain’s sole obligation shall be to replace the non-conforming Software (or defective media) with software that substantially conforms to MicroStrain’s functional specifications for the Software or to refund at MicroStrain’s sole discretion. Except as otherwise agreed by MicroStrain in writing, the replacement Software is provided only to the original licensee, and is subject to the terms and conditions of the license granted by MicroStrain for the Software. Software will be warranted for the remainder of the original Software Warranty Period from the date of original purchase. If a material non-conformance is incapable of correction, or if MicroStrain determines in its sole discretion that it is not practical to replace the non-conforming Software, the price paid by the original licensee for the non-conforming Software will be refunded by MicroStrain; provided that the non-conforming Software (and all authorized copies thereof) is first returned to MicroStrain. The license granted respecting any Software for which a refund is given automatically terminates.

10. Limitation of Liability. IN NO EVENT SHALL THE MICROSTRAIN BE LIABLE FOR SPECIAL, DIRECT, INDIRECT, INCIDENTAL OR CONSEQUENTIAL DAMAGES, INCLUDING BUT NOT LIMITED TO LOSS OF PROFIT OR OPPORTUNITY, OR SIMILAR DAMAGES WHICH MAY ARISE IN CONNECTION WITH ANY OF MICROSTRAIN’S PRODUCTS. BUYER’S SOLE AND EXCLUSIVE REMEDY SHALL IN NO EVENT EXCEED THE REPAIR,

REPLACEMENT OR COST OF THE SPECIFIC PRODUCT PURCHASED FROM MICROSTRAIN AS PROVIDED IN THE WARRANTY PERIOD.

11. Warranty Repair. MicroStrain's sole obligation shall be to repair or replace the defective Product during the applicable Warranty Period at no charge to the original owner or to refund at MicroStrain's sole discretion. Such repair or replacement will be rendered by MicroStrain. The replacement Product need not be new or have an identical make, model or part. MicroStrain may in its sole discretion replace the defective Product (or any part thereof) with any reconditioned Product, or similar Product, that MicroStrain reasonably determines is substantially equivalent (or superior) in all material respects to the defective Product. Repaired or replacement Products will be warranted for the remainder of the original applicable Warranty Period from the date of original purchase. If a material defect is incapable of correction, or if MicroStrain determines in its sole discretion that it is not practical to repair or replace the defective Product, the price paid by the original purchaser for the defective Product will be refunded by MicroStrain upon return to MicroStrain of the defective Product. All Products (or parts thereof) that is replaced by MicroStrain, or for which the purchase price is refunded, shall become the property of MicroStrain upon replacement or refund.

12. Non-Applicability of Warranty. The Limited Warranty provided hereunder for Products will not be applied to and does not cover any refurbished product and any Product purchased through an inventory clearance or liquidation sale or other sales in which MicroStrain, the sellers, or the liquidators expressly disclaim their warranty obligation pertaining to the Product and in that case, the Product is being sold "As-Is" without any warranty whatsoever including, without limitation, the Limited Warranty as described herein, notwithstanding anything stated herein to the contrary.

13. Submitting A Claim. The customer shall return the Product to the original purchase point based on its return policy. In case the return policy period has expired and the Product is within warranty, the customer shall submit a claim to MicroStrain as follows: i) The customer must submit with the Product as part of the claim a written description of the Product defect or Software nonconformance in sufficient detail to allow MicroStrain to confirm the same; ii) The original Product owner must obtain a Return Material Authorization ("RMA") number from MicroStrain and, if requested by MicroStrain, provide written proof of purchase of the Product (such as a copy of the dated purchase invoice for the Product) before the warranty service is provided; iii) After an RMA number is issued, the defective Product must be packaged securely in the original or other suitable shipping package to ensure that it will not be damaged in transit, and the RMA number must be prominently marked on the outside of the package. Do not include any manuals or accessories in the shipping package. MicroStrain will only replace the defective portion of the Product and will not ship back any accessories; iv) The customer is responsible for all in-bound shipping charges to MicroStrain. No Cash on Delivery ("COD") is allowed. Products sent COD will either be rejected by MicroStrain or become the property of MicroStrain. Products shall be fully insured by the customer. MicroStrain will not be held responsible for any packages that are lost in transit to MicroStrain. The repaired or replaced packages will be shipped to the customer via UPS Ground or any

common carrier selected by MicroStrain, with shipping charges prepaid. Expedited shipping is available if shipping charges are prepaid by the customer and upon request; v) Return Merchandise is to be shipped to MicroStrain, Inc. at the address indicated below; vi) MicroStrain may reject or return any Product that is not packaged and shipped in strict compliance with the foregoing requirements, or for which an RMA number has not been obtained or is not visible from the outside of the package. The Product owner agrees to pay MicroStrain's reasonable handling and return shipping charges for any Product that is not packaged and shipped in accordance with the foregoing requirements, or that is determined by MicroStrain not to be defective or non-conforming.

14. What Is Not Covered. This Limited Warranty provided by MicroStrain does not cover: Products, if in MicroStrain's sole and exclusive judgment, have been subjected to abuse, accident, alteration, modification, tampering, negligence, misuse, faulty installation, lack of reasonable care, repair or service in any way that is not contemplated in the documentation for the Product, or if the model or serial number has been altered, tampered with, defaced or removed; Initial installation, installation and removal of the Product for repair, and shipping costs; Operational adjustments covered in the operating manual for the Product, and normal maintenance; Damage that occurs in shipment, due to acts of God, failures due to power surge, and cosmetic damage; Any hardware, software, firmware or other products or services provided by anyone other than MicroStrain; or, Products that have been purchased from inventory clearance or liquidation sales or other sales in which MicroStrain, the sellers, or the liquidators expressly disclaim their warranty obligation pertaining to the Product. Repair by anyone other than MicroStrain will void this Warranty.

15. Copyright Statement. No part of this publication or documentation accompanying any Product may be reproduced in any form or by any means or used to make any derivative such as translation, transformation, or adaptation without permission from MicroStrain as stipulated by the United States Copyright Act of 1976, as amended. Contents are subject to change without prior notice. Copyright© 2007 by MicroStrain, Inc. All rights reserved.

16. Choice of Law. These terms and any agreement between MicroStrain and buyer shall be interpreted in accordance with the substantive laws of the State of Vermont, USA, and without regard to its choice of law provisions. Any action to enforce any such terms shall be exclusively in the courts of competent jurisdiction in Chittenden County, Vermont. Any legal action between MicroStrain and buyer shall be decided by a court, acting without a jury.

17. Disclaimer of U.N. Sale of Goods. The United Nations Convention on Contracts for the International Sale of Goods is specifically disclaimed.

18. Force Majeure. Except for the obligations to make payments, neither party shall be bound to meet any obligation if prevented from doing so as a consequence of force majeure. If a situation of force majeure lasts for more than ninety (90) days, the Parties

shall be entitled to terminate this Agreement by canceling it in writing, without any rights to compensation of damages or refunds.

19. No Assignment. This Agreement, and any Licenses or the Software may not be assigned, sublicensed, leased, sold or otherwise transferred without prior written consent from MicroStrain, and any unauthorized transfer is null and void. This agreement and any licenses granted is personal to you and can be used for personal or internal business use only and may not be used on behalf of a client or customer.

20. Notice. All notifications and communications relating to this Agreement shall be made by the parties to the other party, in writing and shall be signed by a person duly authorized to provide such notice.

21. Entire Agreement. This Agreement shall constitute the entire Agreement between buyer and MicroStrain and shall not be modified or rescinded, except in writing, signed by buyer and MicroStrain. The provisions of this Agreement supersede and precede all prior oral and written quotations, communications, agreements and understandings of the parties. Products and services rendered by MicroStrain are done so only in accordance with these Terms and Conditions of Sale. If any provisions within these terms and conditions are found to be invalid by any court having competent jurisdiction, the invalidity of such provisions shall not affect the validity of the remaining provisions of these terms and conditions, which shall remain in full force and effect.

© 2007 MicroStrain, Inc. All rights reserved. The Products, Software and Embedded Software may be protected by U.S. patents, with other patents pending in the U.S.A. and elsewhere. MICROSTRAIN, MICROSTRAIN and Logo, DEMOD-DC, DVRT, AIFP, STRAINLINK, EMBEDSENSE, FAS-G, FAS-E, FAS-A, 3DM, 3DM-DH, 3DM-G, 3DM-GX1, 3DM-GX2, INERTIA-LINK, MICRO SENSORS. BIG IDEAS., LITTLE SENSORS, BIG IDEAS., V-LINK, G-LINK, SG-LINK, TC-LINK, STRAIN WIZARD, NODE COMMANDER, RHT-LINK, SG-LINK, TORQUELINK, and other marks indicated on our website and the logo forms of the foregoing marks are trademarks and/or service marks of MicroStrain, Inc. and may be registered in the United States or in other jurisdictions including internationally. MicroStrain, Inc.'s trademarks, service marks and trade dress may not be used in connection with any product or service that is not affiliated with MicroStrain, Inc., in any manner that is likely to cause confusion among customers, or in any manner that disparages or discredits MicroStrain, Inc. All other trademarks not owned by MicroStrain, Inc. that appear on MicroStrain's website or in product literature or in manuals, are the property of their respective owners, who may or may not be affiliated with, connected to, or sponsored by MicroStrain, Inc.

Appendix 1: Host-to-Base Station Communication

RS-232

Communication between the Serial base station or the RS-232 interface of the Analog base station *and* the host computer is via a standard RS-232 connection as shown in the RS-232 Signals Definition and RS-232 Asynchronous Character Format tables.

RS-232 Signals Definition

Signal	Name	Direction	Function
TxD	Transmit Data	Host to Base Station	Asynchronous Serial Data from Host
RxD	Receive Data	Base Station to Host	Asynchronous Serial Data to Host
GND	Signal Ground	N/A	Signal Ground Reference

RS-232 Asynchronous Character Format

Baud Rate	115.2K
Parity	None
Data Bits	8
Stop Bits	1

USB 2.0

Communication between the USB base station or the USB interface of the Analog base station *and* the host computer is via a USB 2.0 compliant connection using a Silicon Laboratories CP2101 USB-to-UART Bridge chip on the base station supported by Silicon Laboratories Virtual Communications Port (VCP) drivers installed on the host PC.

Reference is made to the following Silicon Laboratories documents:

[CP2101 Single-Chip USB to UART Bridge Product Brief](#)

[CP2101 Data Sheet](#)

Appendix 2: Datalogging with Agile-Link™ software

Datalogging

- Datalogging allows you to sample each sensor (each channel) on a node from 32 samples per channel per second to 2048 samples per channel per second. Sensor data is written to memory on the node as it is sampled; no transmission occurs to the base station. After the datalogging session has completed, data is downloaded and saved to file by Agile-Link™ software. Analysis is conducted thereafter on the resulting data files. Please review the *Sampling Rates* section of this manual for sampling rate details.

Operating one node in datalogging mode

- A datalogging session should be started by setting your configuration.
- Establish communication with the node and right-click to get the drop-down menu.
- Click Configure. The Configuration window will appear.
- Click the Channels tab. Check boxes to enable G-Link®'s channels 1, 2 and 3. Uncheck the channel 4 box to disable the temperature channel. Leave the Offset scroll boxes for channels 1, 2 and 3 at the default value of 512 (mid-scale). Click Apply.
- Click the Datalogging tab. Uncheck box for Continuous Datalogging. Uncheck box for Enable Sensor Event Driven Trigger. Enter the value 1000 into the Sweeps scroll box. Enter the value 256Hz in the Sample Rate drop-down. Note that a datalogging session of approximately 3.9 seconds has been set. Click Apply. Click OK.
- Click View in the menu bar. Click Channel Actions. The Channel Actions windows will appear.
- Click the Resync button. Channels 1, 2 and 3 will now have the G-Link Calibrator in place indicating that the G-Link® will output engineering units in G's.
- Click the small red X in the upper right corner of the Channel Actions window to close the window.
- Right-click on the node icon/label and a pop-up menu will appear.
- Click Datalogging. Click Erase. A confirming message box will appear. Click Yes. A progress bar will appear and disappear. This indicates that the datalogging memory of the node was successfully erased.
- Right-click on the node icon/label and a pop-up menu will appear.
- Click Datalogging. Click Trigger Session. A progress bar will appear and disappear. This indicates that a datalogging session was successfully triggered.
- Right-click on the node icon/label and a pop-up menu will appear.
- Click Datalogging. Click Download. A progress bar will appear and disappear. This indicates that all datalogging sessions were successfully downloaded.

- Note: Any number of datalogging sessions can be run consecutively before downloading. Please review the *Datalogging Memory* section of this manual for capacity details.
- Right-click on the node icon/label and a pop-up menu will appear.
- Click Datalogging. Click Browse Triggers. The Trigger Browser window will appear.
- Click the + sign to the left of the trigger label (example: July 20, 2007 09:36:07) and Trigger 1 will appear. Highlight Trigger 1 and click the Open Trigger. The data in Trigger 1 will be displayed in spreadsheet format (assuming you have Microsoft® Excel installed). This indicates that the data from Trigger 1 was successfully saved to file on your PC.
- Close the spreadsheet. Click OK on Trigger Browser window.

Operating several nodes in datalogging mode (broadcast method)

- Establish communication with several nodes on the same frequency under one base station.
- Configure each node individually for a datalogging session as described in the *Operating one node in datalogging mode* section above. Normally all nodes would be set to the same sample rate, sweep rate, channel actions, etc. for any given session but there is no requirement to do this.
- Right-click the base station and a drop-down menu appears.
- Click Broadcast and the broadcast menu appears.
- Click Erase. A confirming message box will appear. Click Yes. A progress bar will appear and disappear. This indicates that the datalogging memory of the all the nodes was successfully erased.
- Click Broadcast and the broadcast menu appears.
- Click Trigger. The trigger datalogging command will be broadcast to all nodes. The activity LED on the nodes or elapsed time should be observed to determine when the datalogging session has ended. There is no individual response to Agile-Link™ from the nodes when they are completed datalogging.
- Note: Any number of datalogging sessions can be run consecutively before downloading. Please review the *Datalogging Memory* section of this manual for capacity details.
- Proceed to download datalogging from each node individually as described in the *Operating one node in datalogging mode* section above. Broadcast does not allow downloading of several nodes coincidentally.

Appendix 3: Streaming with Agile-Link™ software

Streaming

Streaming allows you to sample each sensor (each channel) on a node at rates as high as 736 samples per channel per second. Sensor data is transmitted to the base station as it is sampled (in real-time) and is collected, displayed and saved by Agile-Link™ software. Please review the *Sampling Rates* section of this manual for sampling rate details.

Operating one node in streaming mode

- A streaming session should be started by setting your configuration.
- Establish communication with the node and right-click to get the drop-down menu.
- Click Configure. The Configuration window will appear
- Click the Channels tab. Check boxes to enable G-Link®'s channels 1, 2 and 3. Uncheck the channel 4 box to disable the temperature channel. Leave the Offset scroll boxes for channels 1, 2 and 3 at the default value of 512 (mid-scale). Click Apply.
- Click the Streaming tab. Uncheck box for Continuous Streaming. Enter the value 5000 into the Sweeps scroll box. Note that a streaming session of approximately 8 seconds has been set. Click Apply. Click OK.
- Click View in the menu bar. Click Channel Actions. The Channel Actions windows will appear.
- Click the Resync button. Channels 1, 2 and 3 will now have the G-Link Calibrator in place indicating that the G-Link® will output engineering units in G's.
- Click the small red X in the upper right corner of the Channel Actions window to close the window.
- Place the G-Link® on you desktop with the label pointed to the sky and leave it stationary.
- Right-click on the node icon/label and a pop-up menu will appear.
- Click Stream. Click Start. The node will start streaming acceleration in engineering units (Gs) and display the 3 enabled channels as advancing plots on the Real-time Graph. The Y-axis will auto-scale engineering units and will report channel 1 (green) at or near 0 G's, channel 2 (red) at or near 0 G's, and channel 3 (blue) at or near -1 G's. The channel plots will continue along the X-axis until 5000 sweeps (~8 seconds) has elapsed. This indicates that the node is successfully streaming its sensor data.
- Move your mouse pointer within the black area of the Real-time Graph. Right-click and a pop-up menu will appear.
- Click Save Stream. A Save As dialog box appears. Accept or modify the File Name for the CSV file that will be saved. Click Save. The dialog box will disappear. This indicates that the streaming data was successfully saved to file on your PC.

Operating up to 4 nodes in streaming mode (broadcast method)

- Establish communication with up to 4 nodes, each paired with a separate base station and each pair on a different frequency.
- Configure each node individually for a streaming session as described in the *Operating one node in streaming mode* section above. Normally all nodes would be set to the same sweep rate, channel actions, etc. for any given session but there is no requirement to do this.
- Hold down the SHIFT key and click each node once to highlight it.
- Release the SHIFT key. Make sure that only nodes are highlighted; not base stations.
- Right-click on any of the highlighted nodes and a drop-down menu appears.
- Click Stream and the nodes will begin streaming data to separate graphs.
- When the streaming ends, move your mouse pointer within the black area of each Real-time Graph. Right-click and a pop-up menu will appear.
- Click Save Stream. A Save As dialog box appears. Accept or modify the File Name for the CSV file that will be saved. Click Save. The dialog box will disappear. This indicates that the streaming data was successfully saved to file on your PC. Do the same for each node/graph.

Appendix 4: Low Duty Cycle with Agile-Link™ software

Low Duty Cycle

Low Duty Cycle (LDC) allows you to sample each sensor (each channel) on a node from 500 Hz to 1 sample per hour. Sensor data is ‘blipped’ to the base station and collected, displayed and saved by Agile-Link™ software in real-time. Please review the *Sampling Rates* section of this manual for sampling rate details.

Operating one node in LDC

- Low Duty Cycle use should be started by setting your configuration.
- Establish communication with the node and right-click to get the drop-down menu.
- Click Configure and the Configuration window opens.
- Click the Channels tab and apply, as you normally would, the active channels, etc.
- Now click the Low Duty Cycle tab.
- Set the Sample Rate drop-down box to 1Hz, 1 sample per second. *Note:* You may select any of a number of sampling rates ranging from 500 Hz to 1 sample per hour.
- For finite LDC, uncheck the Continuous Low Duty Cycle checkbox.
- Set the Sweeps numscroll to 200, 200 samples over 200 seconds. *Note:* You may select any number of sweeps ranging from 100 to 65500.
- Click Apply.
- Or...
- For continuous LDC, check the Continuous Low Duty Cycle checkbox.
- The Sweeps value is disregarded.
- Click Apply.
- Click OK to close the Configuration window.

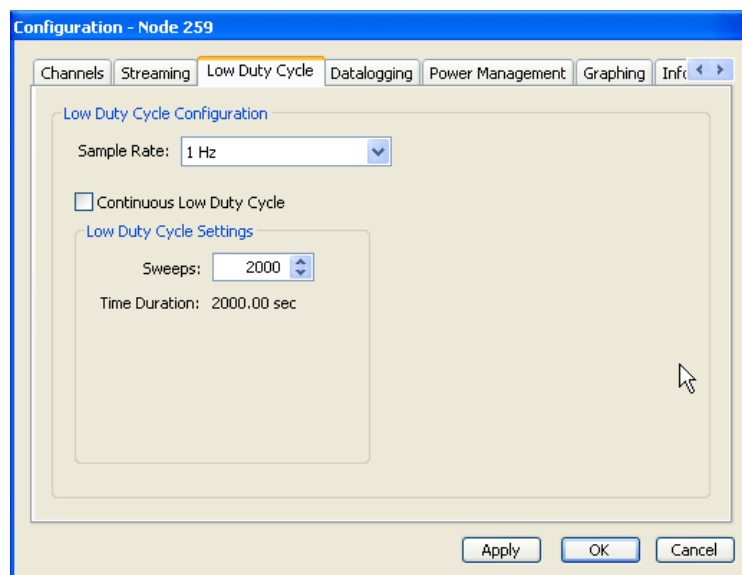

- If you plan to acquire data in engineering units, you should proceed to setting Channel Actions.
- Click View.
- Click Channel Actions.
- The Channel Actions window appears.
- Click Resync to set existing calibrations to the active channels or manually Setup each channel from here. When completed, click the red X in the upper right hand corner of the Channel Actions window to close it.
- To proceed to Low Duty Cycle, right-click the node and the drop-down menu will appear.
- Click Low Duty Cycle.

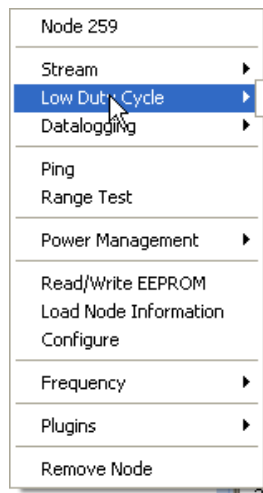

- Click Start and Low Duty Cycle begins sampling and displaying.
- A Data Collector window is spawned in the graphing area.

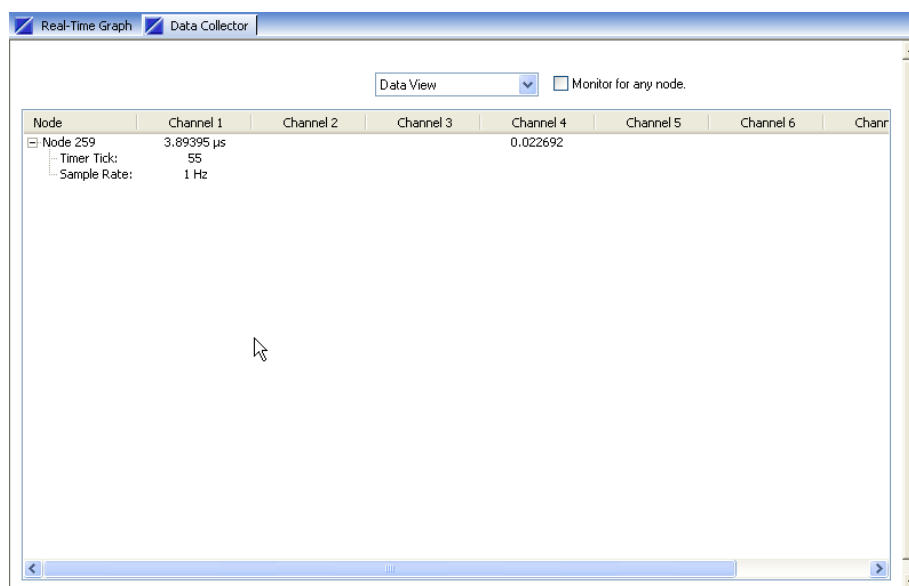

- As Low Duty Cycle samples are received from the node, their values will be displayed by channel. If engineering units have been applied by Channel Actions, the units will display in those units; otherwise all values will be in raw bits.
- Click the + sign to the left of the node and a tree of information will display indicating current Timer Tick (read Sweep) and the current Sampling Rate.
- Select Graph View from the drop-down above the channel headers and the Low Duty Cycle graphing window will appear.
- Click the node in the Available Node frame and a real-time graph will appear and graph the samples as they arrive.

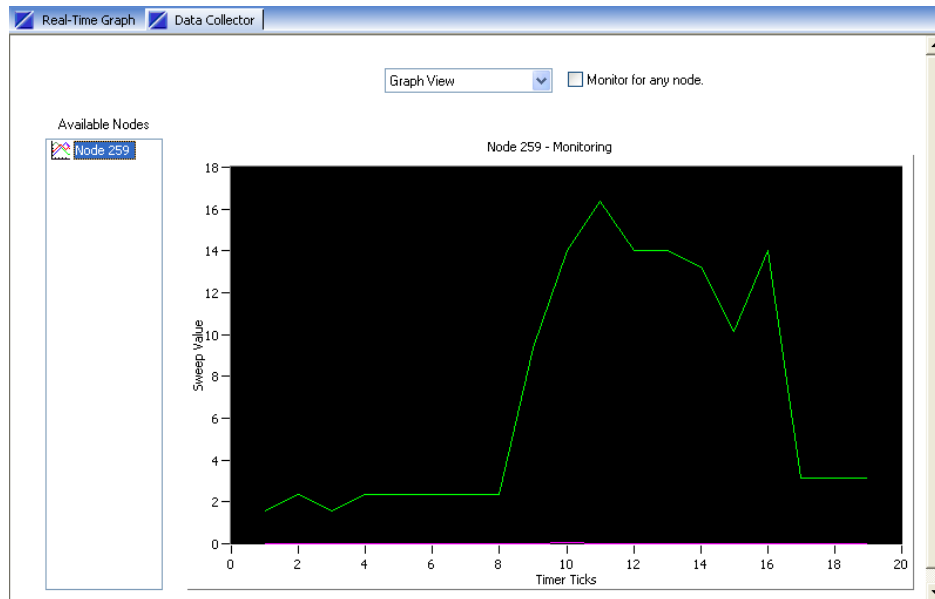

- Select Data View from the drop-down above the channel headers and the Low Duty Cycle data window will reappear.
- In finite Low Duty Cycle, sampling will progress until the number of sweeps set in the Configuration has been reached.
- *Note:* The Agile-Link™ software does not signal the user when a finite LDC session has completed. It will continue to monitor for any samples coming from the node. The user by observation of the Data View, observation of the activity LED on the node, etc. must intervene to continue.
- By right-clicking on the node in the Data Collector window, you receive various menu items.

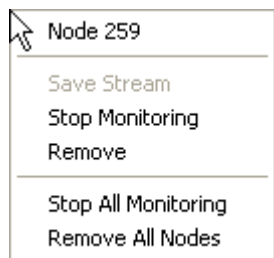

- To stop Low Duty Cycle sampling, click Stop Monitoring.
- To save the Low Duty Cycle session to file, click Save Stream. A 'Save As' window will appear allowing you to name and save the session data. Click OK.
- To close the Data Collector window, click its upper right hand X.
- To return to normal node operations, right-click the node in the Localhost frame to get its main menu.
- *Note:* If you are using continuous Low Duty Cycle sampling or want to prematurely stop a finite Low Duty Cycle sampling, you may do so using the Stop Monitoring and Save Stream software functions. However, the node will continue to operate in Low Duty Cycle mode (and not be able to communicate normally) until you cycle its power. After cycling, you will again be able to communicate normally with the node.

Operating multiple nodes in LDC

- As was stated above, operating multiple nodes in Low Duty Cycle should be started by individually setting each node's configuration and Channel Actions.
- Multiple nodes can be started in Low Duty Cycle at the same instant.
- Press and hold down the Ctrl key.
- Click each node that you want to include in the session.

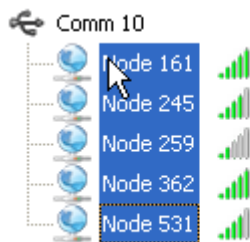

- Release the Ctrl key.
- Right-click the base station and a menu will appear.

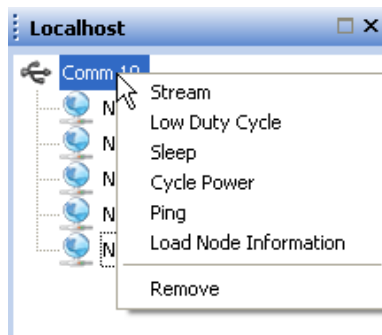

- Click Low Duty Cycle. All nodes that were selected will now begin LDC and will all be sampled by the software.
- *Note:* The nodes will commence at the same instant and although each node runs independently, the nodes will have near real-time synchronization subject to very small error as a result of their individual clock crystals.

- *Note:* Alternatively, all nodes assigned to a base station can be started at the same time. Right-click the base station and click LDC Monitor Node. A Data Collector window will spawn and all nodes will automatically start Low Duty Cycle.
- As before, a Data Collector window is spawned in the graphing area and all nodes being captured are displayed.

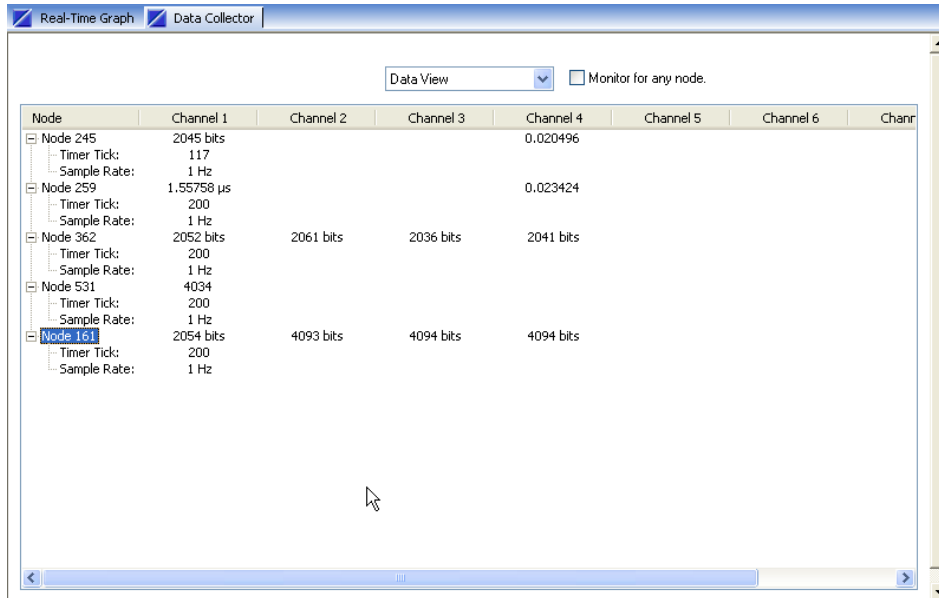

- Click Graph View and the graphing window appears.
- Click the nodes you want to graph in the Available Nodes frame. A limit of 4 graphs on-screen is enforced.

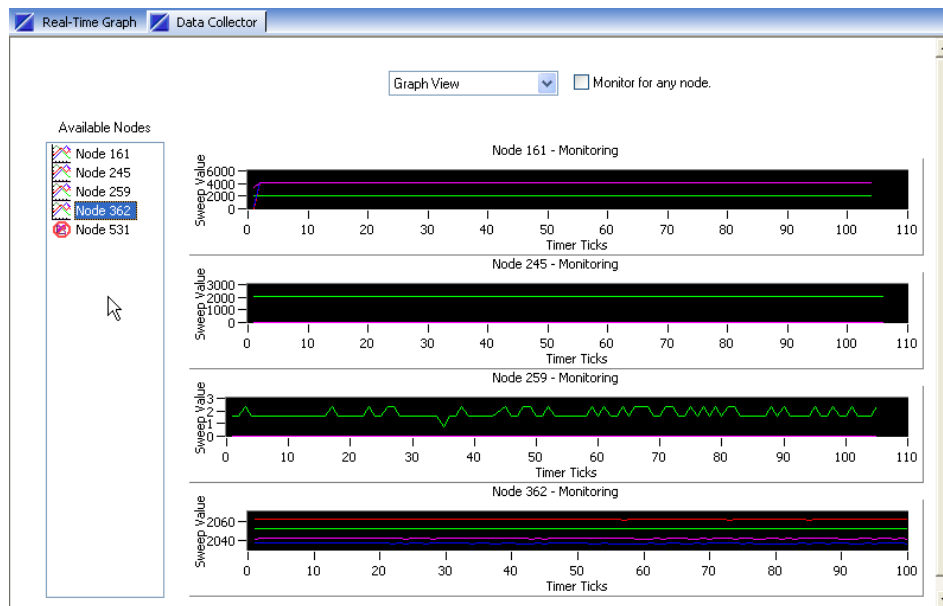

- Return to the Data View, right-click any of the nodes and the menu appears. You can deal with individual nodes as before to Stop Monitoring and/or to Save Stream. You may also click Stop All Monitoring to stop sampling all the nodes at once. **To return to normal operations, all nodes must be stopped.**
- *Note:* The Monitor For Any Node checkbox can be utilized to collect all nodes transmitting LDC or to limit collection to only those nodes selected. Likewise, the Remove Node or Remove All Nodes menu items can be used to throttle collection.
- To close the Data Collector window, click its upper right hand X.

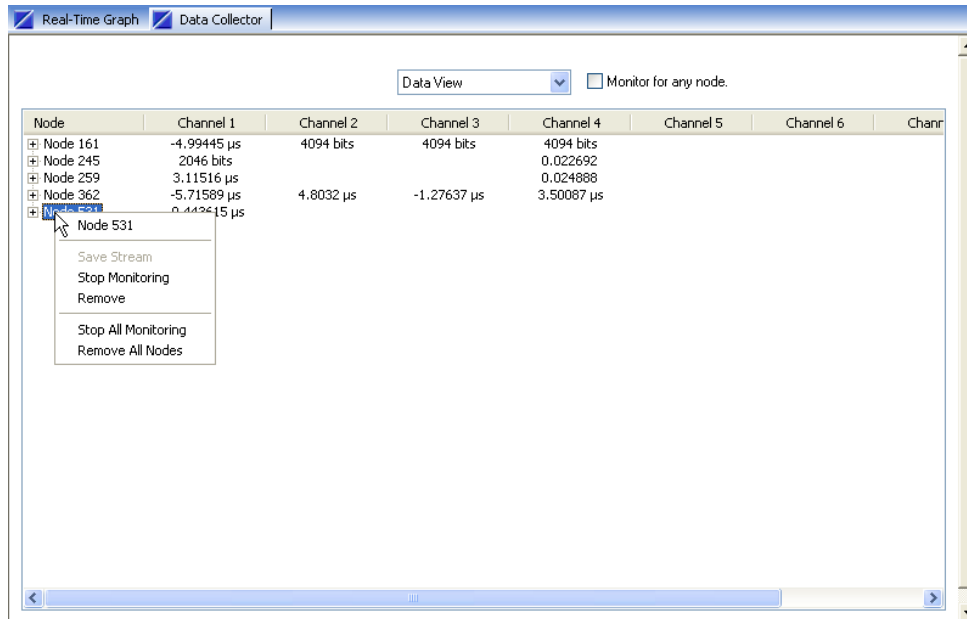

Additional Notes

- In the case of multiple nodes, Low Duty Cycle is not expected to and will not deliver every data sample that is transmitted. Contention occurs and the more nodes you add and the higher sampling rates that you apply add to the overall loss of packets.
- A time stamp based on host time writes out with each row of data in files saved from sessions 1 Hz or slower.

Appendix 5: High Speed Streaming with High Speed Streaming software

High Speed Streaming

High Speed Streaming allows you to sample each sensor (each channel) on a node at rates as high as 4000 samples per channel per second. Sensor data is transmitted to the base station as it is sampled (in real-time) and is collected, displayed and saved by the High Speed Streaming software. Please review the *Sampling Rates* section of this manual for sampling rate details.

Operating one node in high speed streaming mode

Please refer to the High Speed Streaming Quick Start Guide which is contained on the Agile-Link™ CD and on our web site.