

WSDA[®] -Base-104

USB Base Station



Introduction

The WSDA[®] -Base-104 USB Base Station operates as an integral part of MicroStrain[®] mXRS[™] Wireless Sensor Networks. It provides seamless communication between a host PC, single board computer or microcontroller, and single or multiple remote wireless nodes.

Coupled with MicroStrain[®] Node Commander[®] software, the WSDA[®] -Base-104 supports configuration of the wireless nodes including discovery, initialization, radio frequency, sample rate, reading/writing to node EEPROM, calibrating nodes' sensors, managing the nodes' batteries including sleep, wake and cycle power, and upgrading the nodes' firmware.

The WSDA[®] -Base-104 supports all data acquisition sessions between wireless nodes and host computers including Synchronized Sampling (both Continuous and Burst modes), Armed Datalogging, Datalogging, Streaming and Legacy Low Duty Cycle.

Features & Benefits

- Support for hundreds of simultaneously sampling wireless sensor nodes
- Node to node synchronization of +/- 32 microseconds
- Ultra-stable on-board precision timing reference of +/- 3 ppm over industrial temperature range
- Extended wireless communication range to 2 km
- USB 2.0 @ 921,000 baud

Applications

- Condition based monitoring of machines and aircraft
- Health monitoring of civil structures and vehicles
- Embedded OEM sensing systems
- Smart structures and materials
- Experimental test and measurement
- Robotics and machine automation
- Vibration and acoustic noise testing
- Sports performance and sports medicine analysis
- Distributed security networks

System Overview

At the heart of MicroStrain's mXRS[™] Wireless Sensor Networks is the WSDA[®] -Base, which uses our exclusive beaconing protocols to synchronize precision timekeepers embedded within each sensor node in the network. The WSDA[®] -Base also coordinates data collection from all sensor nodes. Users can easily program each node on the scalable network for simultaneous, periodic, or burst mode sampling with our Node Commander[®] software, which automatically configures network radio communications to maximize the aggregate sample rate.

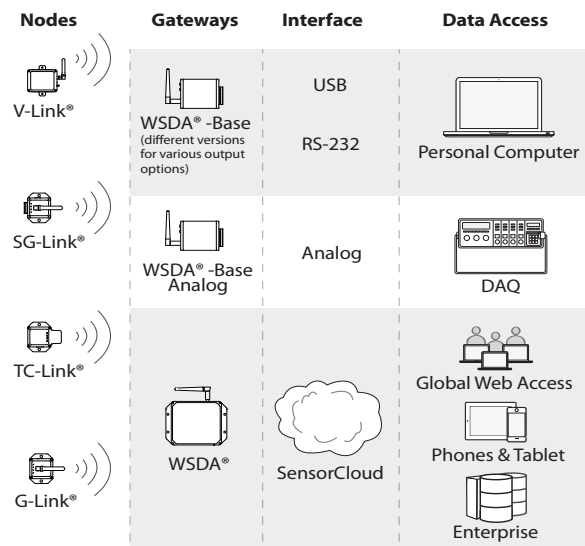

Specifications

| | |
|--|--|
| Node support | V-Link®-mXRS™ SG-Link®-mXRS™ G-Link®-MXRS™ DVRT-Link™-mXRS™ TC-Link®-6CH-mXRS™ TC-Link®-1CH-mXRS™ EH-Link® SG-Link® OEM-S TC-Link® OEM all legacy 2.4 GHz wireless nodes |
| Host communication interface | USB 2.0 virtual serial communication @ 921,600 bps |
| Communication cable | 3 foot USB standard to USB micro-B |
| Power | USB @ 5 volt standard |
| Power consumption | 65.6 mA - 8 active node channels operating at 256 Hz Legacy Low Duty Cycle with analog outputs active 45.7 mA - Idle |
| Radio frequency (RF) transceiver carrier | 2.4 GHz direct sequence spread spectrum, license free worldwide (2.405 to 2.480 GHz) – up to 16 channels, radiated power programmable from 0 dBm (1 mW) to 16 dBm (39 mW) |
| RF data packet standard | IEEE 802.15.4, open communication architecture |
| Range for bi-directional RF link | 16 dBm (39 mW) Extended Power with range up to 2 kilometers (not available in Europe) 10 dBm (10 mW) Standard Power with range up to 1 kilometer 0 dBm (1 mW) Low Power with range up to 70 meters |
| Node synchronization | 1 Hz beacon provides +/-32 microsecond node to node synchronization |
| Status LED | multi-color LED signals activity status |
| Operating temperature | -40 °C to +85 °C electronics only; -30 °C to +70 ° with standard enclosure |
| Dimensions | 88 mm x 70 mm x 20 mm without antenna |
| Weight | 126 grams |
| Enclosure material | black anodized aluminum |
| Software | Node Commander® Windows XP/Vista/7 compatible |
| Software development kit | includes Data Communication Protocol and sample code |
| FCC ID | XJQMSLINK0001 |
| IC ID | 8505A-MSLINK0001 |

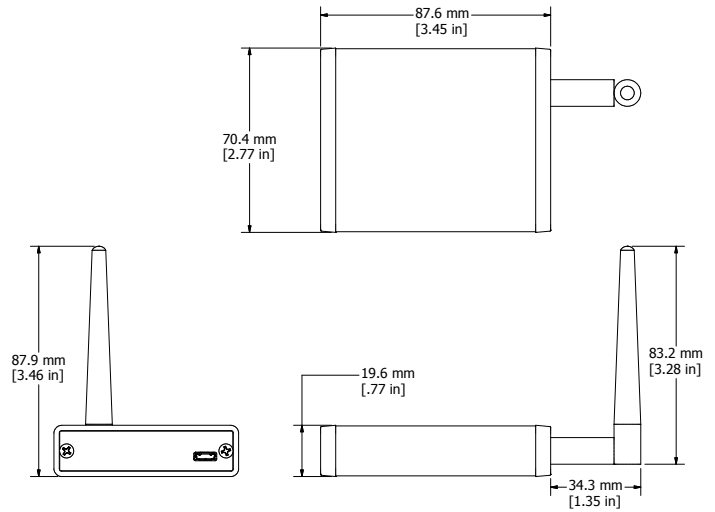

 **MicroStrain®**

MicroStrain Inc.
459 Hurricane Lane,
Suite 102
Williston, VT 05495 USA
www.microstrain.com

ph: 800-449-3878
fax: 802-863-4093
sales@microstrain.com