

Extended Range Synchronized 6 Channel Wireless Thermocouple Node



Introduction

The TC-Link[®] -6CH -mXRS[™] complete wireless thermocouple node, designed for integration with wireless sensor networks, combines full thermocouple conditioning with award-winning MicroStrain[®] wireless systems.

This amazing new wireless sensor node features six standard thermocouple input connectors with an embedded cold junction temperature sensor. On-board linearization algorithms are software programmable to support a wide range of thermocouple types (J, K, N, R, S, T, E, B).

The node can simultaneously log data to internal memory and transmit real-time data to a base station transceiver at a pre-programmed rate, where data is displayed and logged for further analysis. And because each node has a unique address, a single host transceiver can address hundreds of sensor nodes.

Features & Benefits

- plug and play: quickly add wireless sensing and logging capabilities to existing thermocouples and probes
- supports type J, K, N, R, S, T, E, B thermocouples with on-board cold junction compensation
- low cost per channel, with 6 thermocouples per node and simultaneous acquisition from multiple nodes
- self-calibrating 24 bit sigma-delta analog to digital converter
- sample rates from 2 Hz to 1 sample every 17 minutes
- 2.4 GHz IEEE 802.15.4 spread spectrum radio with 70m line-of-sight range (100 m with high gain antenna), license free worldwide
- optional relative-humidity sensor
- on-board real-time clock
- Internal rechargeable battery and low-power consumption for extended use
- SensorCloud[™] ready

Applications

- civil structures sensing: concrete maturation
- industrial sensing networks: machine thermal management
- food and transportation systems: refrigeration, freezer performance monitoring
- advanced manufacturing: plastics processing, composite cure monitoring
- assembly line testing with smart packaging
- cryogenic applications

System Overview

At the heart of MicroStrain's extended range synchronized (mXRS[™]) system is the WSDA[®]-Base, which uses our exclusive beaconing protocols to synch precision timekeepers embedded within each sensor node in the network. The WSDA[®]-Base also coordinates data collection from all sensor nodes, including TC-Link[®] -6CH -mXRS[™]. Users can easily program each node on the scalable network for simultaneous, periodic, or burst mode sampling with our Node Commander[®] software, which then automatically configures network radio communications to maximize the aggregate sample rate.

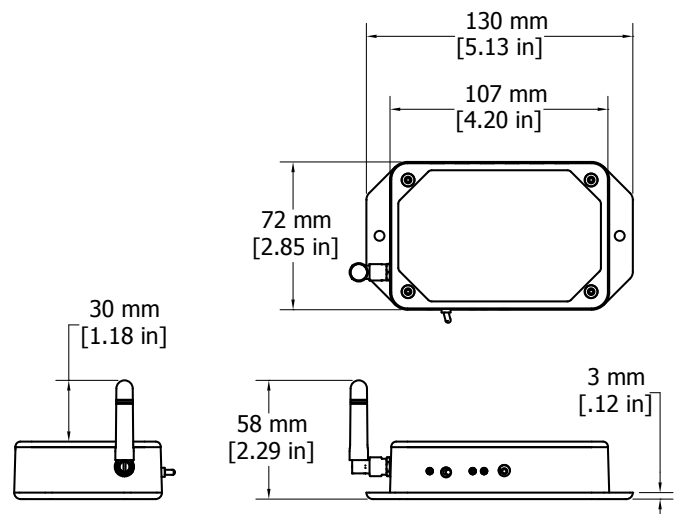



Specifications

Thermocouple inputs supported	software selectable: type-J, K, N, R, S, T, E, B six-input channel, one ambient CJC channel
Standard thermocouple measurement range	J: -210 to 760 °C; K: -200 to 1372 °C; N: -200 to 1300 °C; R: -50 to 1664 °C; S: -50 to 1664 °C; T: -200 to 400 °C; E: -200 to 1000 °C; B: 250 to 1820 °C
Temperature measurement accuracy	± 0.1 % full scale or ±2 °C, whichever is greater (does not include errors due to TC wire or transducer)
Temperature repeatability	±0.1 °C (does not include errors due to TC wire or transducer)
Temperature resolution	0.0625 °C
Cold junction compensation range	-20 to 85 °C
Thermocouple connector	six type-1, standard, mini (SM) connectors for flat pin TC inputs
Optional relative humidity (RH) sensor	range 0 to 100 % RH, accuracy ± 2 % RH (from 10 to 90 % RH), repeatability ± 0.1 % RH
Analog to digital (A/D) converter	24 bit sigma-delta A/D
Sample Rate	programmable from 2 samples/second to 1 sample/17 minutes for datalogging or LDC modes
Datalogging mode	log up to 90,000 data sets (up to 630,000 data points)
Nodes per gateway	supports up to 100 nodes per gateway
Sample rate stability	datalogging and LDC modes ±25 ppm
Radio frequency (RF) transceiver carrier	2.4 GHz direct sequence spread spectrum, license free worldwide (2.405 to 2.480 GHz) – 16 channels, radiated power programmable from 0 dBm (1 mW) to 20 dBm (100 mW); European models limited to 10 mW
Range for bi-directional RF link	programmable communication range from 70m to 2,000m
RF data packet standard	IEEE 802.15.4, wireless communication architecture
PC Communications	115,200 baud over USB
Internal Li-ion battery	rechargeable 3.7 volt lithium ion, 740 mAh capacity, customer may also supply external power from 3.2 to 9 volts
Power consumption (battery life)	2 samples per second - 0.8 mA (1 month) 1 sample per second - 0.48 mA (2 months) 3 samples per minute - 0.1 mA (8 months) 1 sample per minute - 0.09 mA (10 months)
Operating temperature	-20 to +60 °C with standard internal battery and enclosure, extended temperature range optional with custom battery and enclosure; -40 to +85 °C for electronics only
Maximum acceleration Limit	500 g standard (high g option available)
Dimensions	130 mm x 72 mm x 28 mm (enclosure without antenna)
Weight	142 grams (with enclosure)
Enclosure Material	ABS plastic
Compatible Base Stations	WSDA®, WSDA® -Base (Analog), WSDA® -Base (USB/RS-232)
Software	Node Commander® Windows XP/Vista/7 compatible

