

Inertia-Link[®]

Inertial Measurement Unit and Vertical Gyro



Introduction

Inertia-Link[®] is a high-performance Inertial Measurement Unit and Vertical Gyro utilizing miniature MEMS sensor technology. It combines a triaxial accelerometer, triaxial gyro, temperature sensors, and an on-board processor running a sophisticated sensor fusion algorithm.

Inertia-Link[®] offers a range of output data quantities from fully calibrated inertial measurements (acceleration & angular rate or deltaAngle & deltaVelocity vectors) to computed orientation estimates (pitch & roll or rotation matrix). All quantities are fully temperature compensated and corrected for sensor misalignment. The angular rate quantities are further corrected for G-sensitivity and scale factor non-linearity to third order.

Inertia-Link's communications interface hardware is contained in a separable module, and can therefore be easily customized. Currently available interface modules include a wireless transceiver, USB 2.0, RS232 and RS422. An OEM version is available without the communications interface enabling the sensor to be integrated directly into a host system's circuitboard, providing a very compact sensing solution.

Features & Benefits

- small, light-weight, low-power design ideal for size-sensitive applications including wearable devices
- fully temperature compensated over entire operational range
- calibrated for sensor misalignment, gyro G-sensitivity, and gyro scale factor non-linearity
- simultaneous sampling for improved time integration performance
- available with wireless and USB communication interfaces
- user adjustable data rate (1 to 250Hz) and sensor bandwidth (1 to 100Hz)
- outputs include Euler angles, rotation matrix, deltaAngle & deltaVelocity, acceleration and angular rate vectors

Applications

- inertial aiding INS and GPS, location tracking
- unmanned vehicles, robotics – navigation, artificial horizon
- computer science, biomedical – animation, linkage free tracking/control
- platform stabilization
- antenna and camera pointing





The system architecture has been carefully designed to substantially eliminate common sources of error such as hysteresis induced by temperature changes and sensitivity to supply voltage variations. The use of six independent Delta-Sigma A/D converters (one for each sensor) ensures that all sensors are sampled simultaneously, and that the best possible time integration results are achieved. On-board coning and sculling compensation allows for use of lower data output rates while maintaining performance of a fast internal sampling rate.

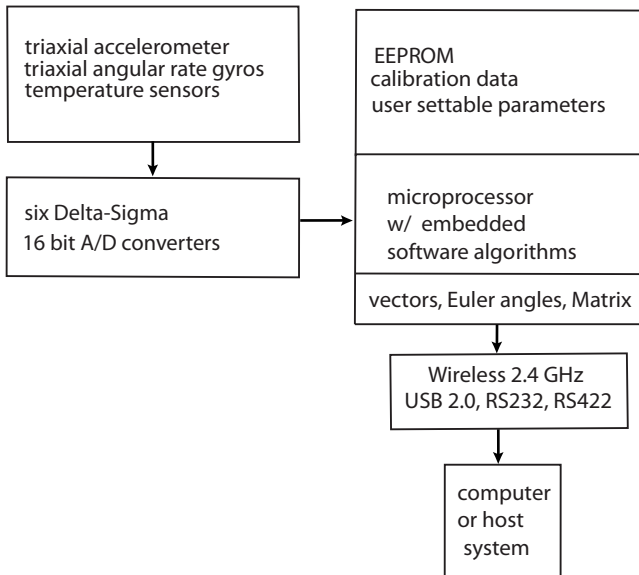

Specifications

Orientation range (pitch, roll, yaw)	360° about all axes
Accelerometer range	accelerometers: $\pm 5 g$ standard $\pm 10 g$ and $\pm 2 g$ also available
Accelerometer bias stability	$\pm 0.010 g$ for $\pm 10 g$ range $\pm 0.005 g$ for $\pm 5 g$ range $\pm 0.003 g$ for $\pm 2 g$ range
Accelerometer nonlinearity	0.2%
Gyro range	gyros: $\pm 300^\circ/\text{sec}$ standard, $\pm 1200^\circ/\text{sec}$, $\pm 600^\circ/\text{sec}$, $\pm 150^\circ/\text{sec}$, $\pm 75^\circ/\text{sec}$ also available
Gyro bias stability	$\pm 0.2^\circ/\text{sec}$ for $\pm 300^\circ/\text{sec}$
Gyro nonlinearity	0.2%
A/D resolution	16 bits
Orientation Accuracy	$\pm 0.5^\circ$ typical for static test conditions $\pm 2.0^\circ$ typical for dynamic (cyclic) test conditions & for arbitrary orientation angles
Orientation resolution	$<0.1^\circ$ minimum
Repeatability	0.20°
Output modes	acceleration and angular rate, deltaAngle and deltaVelocity, Euler angles, rotation matrix
Interface options	RS232, RS422, USB 2.0 and wireless - 2.45 GHz IEEE 802.15.4 direct sequence spread spectrum, license free worldwide (2.450 to 2.490 GHz) - 16 channels
Wireless communication range	70 m
Digital output rates	1 to 250 Hz with USB interface 1 to 100 Hz with wireless interface
Serial data rate	115200 bps
Supply voltage	5.2 to 9.0 volts
Power consumption	90 mA
Connectors	micro DB9
Operating temp.	-40 to +70°C with enclosure -40 to +85°C without enclosure
Dimensions	41 mm x 63 mm x 24 mm with enclosure 32 mm x 36 mm x 15 mm without enclosure
Weight	39 grams with enclosure, 16 grams without enclosure
Shock limit	1000 g (unpowered), 500g (powered)

*Accuracy and stability specifications obtained over operating temperatures of -40 to 70°C with known sine and step inputs, including angular rates of $\pm 300^\circ$ per second.



MicroStrain Inc.
 310 Hurricane Lane, Unit 4 ph: 800-449-3878
 Williston, VT 05495 USA fax: 802-863-4093
 www.microstrain.com sales@microstrain.com