

ENV-Link® -Mini -LXRS®

Wireless Environmental Sensor Node

The LORD MicroStrain® ENV-Link® -Mini -LXRS® is an environmental monitoring node designed to continuously acquire sensor data in outdoor or harsh settings. The ENV-Link® -Mini -LXRS® accommodates a relative humidity/temperature (RHT) sensor, and 3 additional 0-5 VDC sensors. Possibilities include pyranometer (light measurement), soil moisture, leaf wetness, rain gauge, wind speed and direction, water level, barometric pressure, conductivity, strain gauges, thermocouples, etc. Multiple units may be deployed up to 2 kilometers from the wireless gateway, and data is either stored locally or forwarded to a cloud server, providing analysis tools, scripting, alerts, and downloads. Long-life batteries allow long term unattended data acquisition.



Features & Benefits

High Performance

- SensorCloud web based environmental monitoring
- Scalable, ultra-long-range wireless sensor network
- Lossless data throughput under most operating conditions
- Low-power for extended battery life

Ease of Integration

- Rapidly deployable wireless form factor
- Simple integration supported by comprehensive SDK

Cost Effective

- Reduced cost and rapid time to market for custom applications
- Aggressive volume discount schedule

Applications

- environmental monitoring
- precision agriculture
- crop maintenance
- ecological research
- smart building HVAC monitoring
- solar and wind surveying

System Overview

At the heart of MicroStrain® LXRS® Wireless Sensor Networks are WSDA® gateways, which use our exclusive beaconing protocols to synchronize precision timekeepers embedded within each sensor node in the network. The WSDA® also coordinates data collection from all sensor nodes. Users can easily program each node on the scalable network for simultaneous, periodic, or burst mode sampling with our Node Commander® software, which automatically configures network radio communications to maximize the aggregate sample rate.

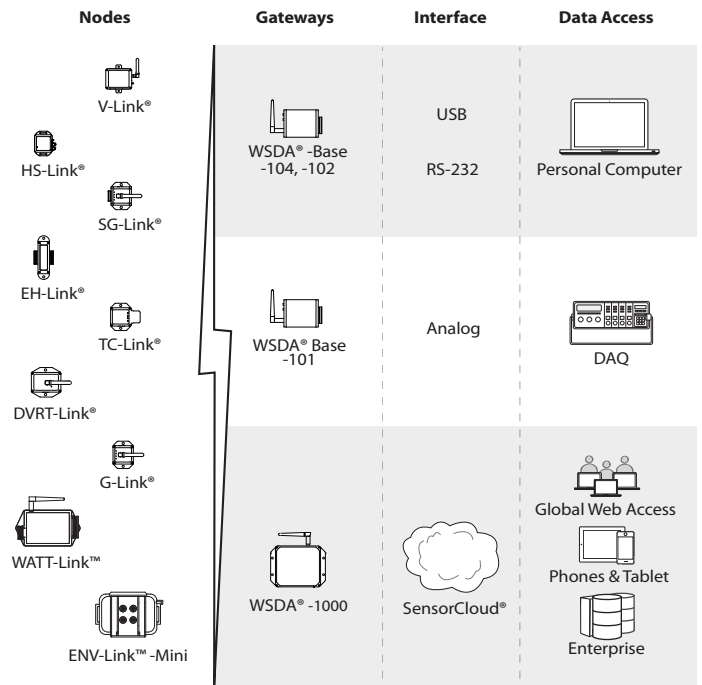

Wireless Sensor Network (WSN)

ENV-Link® -Mini -LXRS® Wireless Environmental Monitoring Node

Specifications

Number of sensor channels	supports 1 relative humidity/temperature sensor and three 0-5 VDC sensors
Optional sensors	relative humidity/temperature, pyranometer, photosynthetic photon flux, soil moisture, and leaf wetness (all available from Microstrain®)
Sensor excitation	2 or 3 V (user selectable)
Connectors	IP67 bayonette
Analog to digital (A/D) converter	24 bit sigma-delta A/D
Sample Rate	2 Hz to as low as 1 sample every 17 minutes
Nodes per base station	up to 100 nodes supported per base station
Sample rate stability	LDC mode ± 25 ppm
Data logging capacity	log up to 540,000 data points
Radio frequency (RF) transceiver carrier	2.4 GHz direct sequence spread spectrum, license free worldwide (2.405 to 2.480 GHz) – up to 16 channels, radiated power programmable from 0 dBm (1 mW) to 20 dBm (100 mW)
Range for bi-directional RF link	user selectable up to 2 km line-of-sight
RF data packet standard	IEEE 802.15.4, wireless communication architecture
Internal batteries	2 x 3.6 V lithium ion AA batteries (supplied with unit) or 2 x 1.5 V alkaline AA batteries (user supplied)
Power input range	0.9 to 6.0 VDC
Operating temperature	-40 to +60 °C with alkaline internal battery and enclosure
Dimensions	150 mm wide x 53 mm high x 104 mm deep
Weight	298 grams
Enclosure	IP-67
Compatible base stations	WSDA® -Base, WSDA® -1000
Software	Node Commander® for Windows XP/Vista/7, SensorCloud™

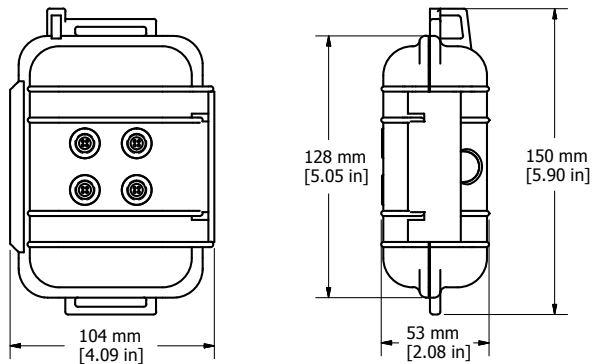
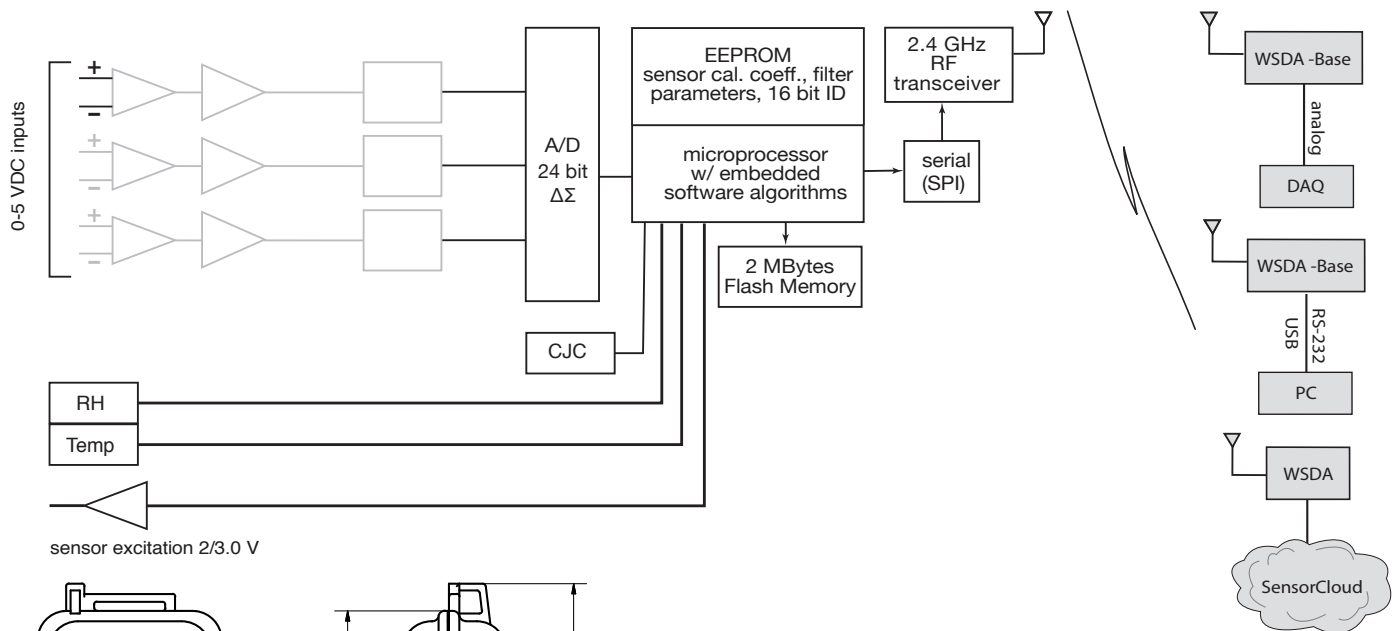

Digital Relative Humidity and Temperature Sensor

This option is a surface mountable relative humidity and temperature sensor. A unique capacitive sensor element is used for measuring relative humidity while temperature is measured by a band-gap sensor. Both sensors are seamlessly coupled to a 14 bit analog to digital converter and a serial interface circuit. Each is individually calibrated in a precision humidity chamber. The calibration coefficients are programmed into an OTP memory on the chip. These coefficients are used to internally calibrate the signals from the sensors.



Specifications

Relative Humidity					
Parameter	Condition	min	typ	max	Units
Resolution		0.4	0.05	0.05	%RH
		8	12	12	bit
Accuracy	typical		±2.0		%RH
	maximal	see Figure 1			
Repeatability			±0.1		%RH
Hysteresis			±1		%RH
Non-linearity	linearized		<<1		%RH
Response time	τ (63%)		8		s
Operating range		0	100		%RH
Long term drift	normal		< 0.5		%RH/yr
Temperature					
Resolution		0.04	0.01	0.01	°C
		12	14	14	bit
Accuracy	typical		±0.3		°C
	maximal	see Figure 2			
Repeatability			±0.1		°C
Operating range		-40		123.8	°C
		-40 254.9 °F		254.9	°F
Response time	± (63%)	5		30	s
Long term drift			< 0.04		°C/yr
General					
Cable	5 meters with 4 pin IP-67 Binder connector				
Dimensions	54 mm (L) x 21 mm (D)				
Weight	36 g (with 0.6 m lead wire)				

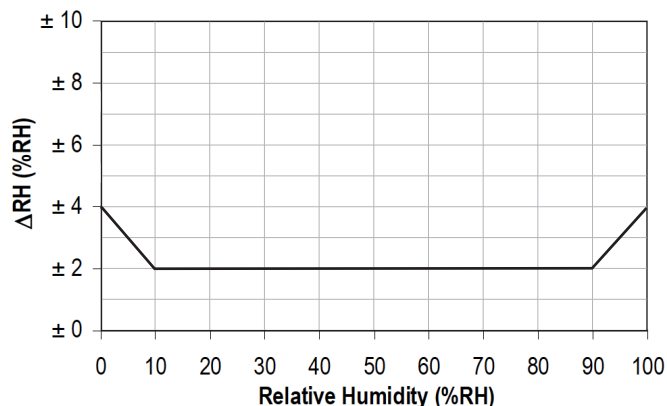

Figure 2: Maximal RH-tolerance at 25°C per sensor type.

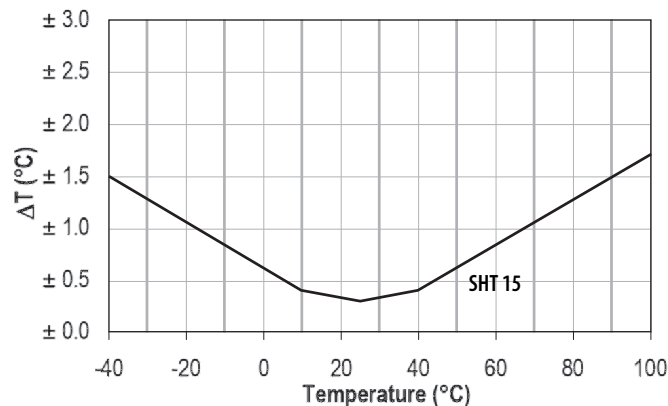

Figure 3: Maximal T-tolerance per sensor type.

Silicon-Cell Photodiode Pyranometer Sensor

This silicon-cell pyranometer is calibrated to measure total shortwave radiation. The evaporation of water from soil and the transpiration of water from plant leaves are largely determined by the intensity of shortwave radiation, which is measured in watts per meter squared. This cosine-corrected sensor is designed to maintain its accuracy when radiation comes from low zenith angles.



Specifications

Cosine response	45° zenith angle: ± 1%, • 75° zenith angle: ± 5%
Repeatability	± 1%
Absolute accuracy	± 5%
Sensitivity	custom calibrated to exactly 5.00 W/m ² per mV
Input power	none, self-powered
Output	responsivity: 0.20 mV per W/m ² , In Full Sunlight: 220 mV (1100 W/m ²), Linear Range: 0 - 350 mV (0 - 1750 W/m ²); 1.75 full sun
Operating environment	-40 to 55° C, 0 to 100% relative humidity, designed for continuous outdoor use, can be submerged in water
Cable	5 meters of twisted-pair wire, foil shield, Santoprene jacket, with 4 pin IP-67 Binder connector; additional cable is available in multiples of 5 meters
Uniformity	± 3%
Materials	anodized aluminum with cast acrylic lens
Shortwave radiation operating range	0 - 1750 W/m ² (1.75 full sun)
Dimensions	28.32mm H x 23.50mm D
Weight	90 g (with 5 m lead wire)
Mounting	optional leveling plate

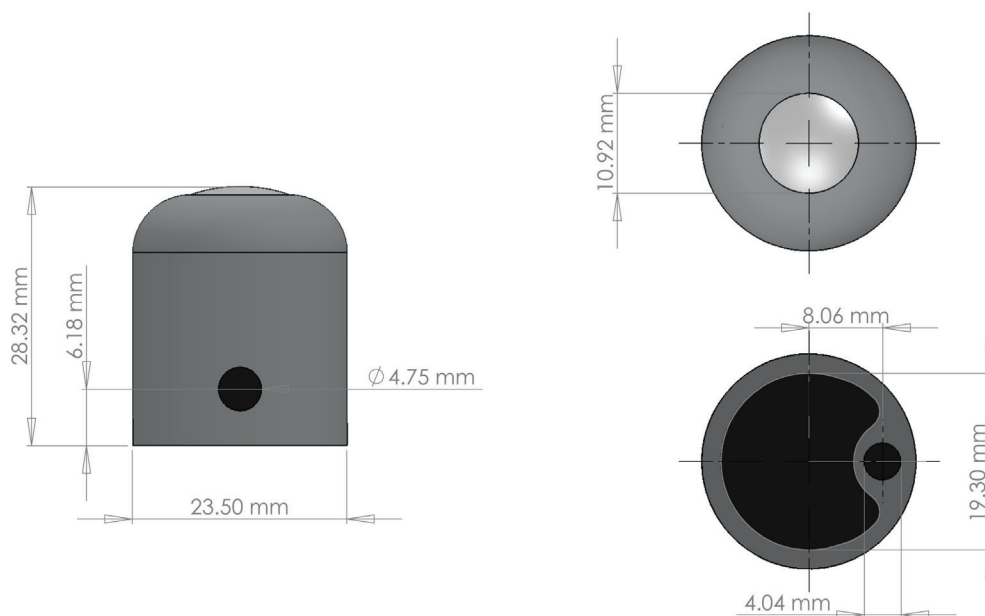

Photosynthetic Photon Flux Sensor

An innovative blue lens improves the accuracy of these sensors. The pigments in the lens filter incoming light for an improved spectral response. Photosynthesis is driven by the number of photons between 400 and 700 nanometers (nm). This is called the Photosynthetic Photon Flux (PPF) and is measured in $\mu\text{mol}/\text{m}^2/\text{s}$ (micromols of photons per square meter per second). PPF sensors are commonly called quantum sensors because a quantum refers to the amount of energy carried by a photon.



Specifications

Cosine response	45° zenith angle: $\pm 1\%$, 75° zenith angle: $\pm 5\%$
Repeatability	$\pm 1\%$
Absolute accuracy	$\pm 5\%$
Long-term drift	less than 3% per year
Quantum response	400 to 700 nm
Input power	none, self-powered
Output	$\mu\text{mol}/\text{m}^2/\text{s}$
Operating environment	-25 to 55 °C, 0 to 100% relative humidity, designed for continuous outdoor use, can be submerged in water
Cable	5 meters of twisted-pair wire, foil shield, Santoprene jacket with 4 pin IP-67 Binder connector; additional cable is available in multiples of 5 meters
Materials	anodized aluminum with cast acrylic lens
Dimensions	27.79 mm (H) x 23.85 mm (D)
Weight	90 g (with 5 m lead wire)
Mounting	optional leveling plate

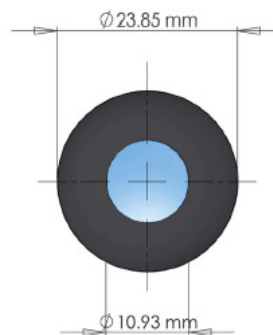

Leaf Wetness Sensor

The optional leaf wetness sensor is standardized, calibrated, and designed to detect wetness (presence and duration) and ice formation right out of the box. No painting, baking, or user calibration required. Each sensor is precisely factory-calibrated to detect tiny amounts of water and ice on the leaf surface. The sensor surface coating is not hydroscopic, eliminating false wetness detection. The sensor's thin (0.65mm) fiberglass construction closely approximates the heat capacity of a typical leaf, and its overall radiation balance closely matches that of a healthy leaf.



Specifications

Measurement speed	10 mS
Sensor type	frequency domain
Output	320-1000 mV @ 3V excitation
Operating environment	-40 °C to +50 °C
Power	2.5 VDC @ 2 mA, to 5 VDC @ 7 mA
Wetness operating range	445 counts (dry) to 1400 counts (saturated)
Resolution	1 raw count
Accuracy	+/- 10 raw counts
Repeatability	2 thresholds
Cable	5 meters with 4 pin IP-67 Binder connector
Dimensions	11.2 cm x 5.8 cm x .075 cm
Weight	139 g (with 5 m lead wire)

Soil Moisture Probe Sensor

The optional soil moisture probe enables low cost monitoring of volumetric water content (VWC) by measuring the dielectric constant of the media using capacitance/frequency domain technology. Its 70 MHz frequency minimizes salinity and textural effects, making this sensor accurate in almost any soil or soilless media. Factory calibrations are included for mineral soils, potting soils, rockwool, and perlite. This handy little sensor is easy to install in the field and can also be used in nursery pots. The robust design makes it easy to push directly into undisturbed soil to ensure good accuracy. It consumes only 10 mA of power and operates over a wide temperature range.



Specifications

Accuracy	mineral soil: ±3% VWC, most mineral soils, up to 8 dS/m ±1-2% VWC with soil specific calibration Rockwool: ±3% VWC, 0.5 to 8 dS/m Potting Soil: ±3% VWC, 3 to 14 dS/m Resolution
Resolution	0.1% VWC (mineral soil) 0.25% VWC (rockwool)
Range	calibration dependant; up to 0-100% VWC with polynomial equation
Measurement time	10 ms
Power	2.5 - 3.6 V DC @ 10 mA. Output proportional to input voltage. 2.5 V and 3 V excitations supported with calibration equations
Output	voltage, correlated linearly (soil) or polynomially (growing media) with VWC
Temperature	-40°C to +50°C
Cable	5 meters with 4 pin IP-67 Binder connector
Dimensions	93 mm (L) x 18 mm (W)
Weight	132 g (with 5 m lead wire)

Sensor Cable

The optional sensor cable provides an off-the-shelf and easy solution to connect your specific sensor to the ENV-Link™-Mini-LXRS®.



Specifications

Input range	0-5 V
Sensor input types	Single-ended or differential
Sensor excitation	2 or 3 V (user selectable)
Cable length	36 inches
Cable connector	4 pin IP-67 Binder
Pigtail leads	Red Power Black Ground Green Sensor + White Sensor -