

## V-Link<sup>®</sup> –mXRS<sup>™</sup> Pin Assignments

### Terminal Block Connectors

The V-Link<sup>®</sup> has two 15-pin terminal blocks mounted on the sidewall of the enclosure. These terminal blocks accommodate the 4 differential input channel sensor connections, the 3 single ended channel sensor connections, and an external power connection. The two female connectors made into the sidewall of the enclosure are Weidmuller Model SL-SMT 3.50/15/90G 3.2SN BK BX. The two removable male connectors are Weidmuller BL 3.50/15/180 SN BK BX. Specific details on these connectors may be found at: <http://www.weidmuller.com>

**Tip:** Strain gauge leads may be beefed up by tinning and/or adding stiff wire to the end of the lead so that the leads are held firmly in the terminal block connector. Loose connections will cause erroneous readings.

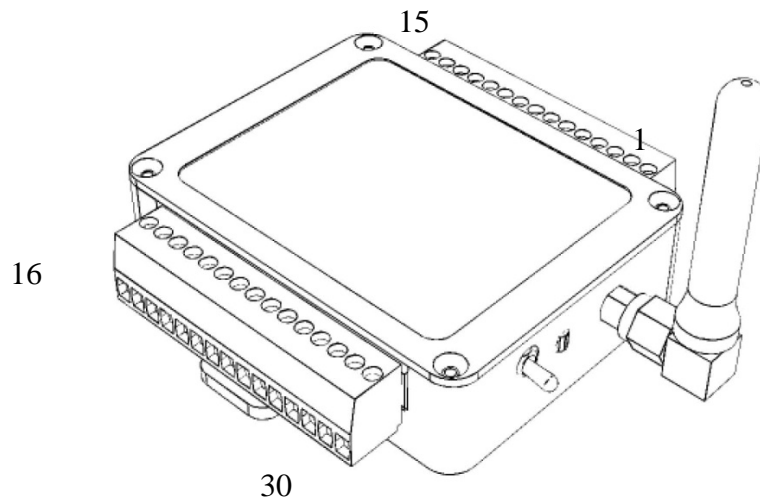

**Figure 1. V-Link<sup>®</sup> connector blocks**

1. SP+	30. P+ (Vaux)
2. S1+	29. GND
3. S1-	28. NC
4. GND	27. NC
5. S1 S	26. GND
6. SP+	25. Ain7
7. S2+	24. GND
8. S2-	23. Ain6
9. GND	22. GND
10. S2 S	21. Ain5
11. SP+	20. S4 S
12. S3+	19. GND
13. S3-	18. S4-
14. GND	17. S4+
15. S3 S	16. SP+

**Table 1. Pin numbering and brief nomenclature**

## Pin Numbering, Nomenclature and Use

Signal Name	Reference	Direction	Description
Pin 1: Sensor Power	SP+	Output	This signal provides output power to external sensors. This output is only active (“on”) when the unit is sampling the sensors. Maximum combined load on this pin and all other SP+ pins is 50 mA.
Pin 2: Channel 1 Sensor Differential Amplifier Input +	S1+	Input	This is the positive input to the channel 1 PGA.
Pin 3: Channel 1 Sensor Differential Amplifier Input -	S1-	Input	This is the negative input to the channel 1 PGA.
Pin 4: Ground	GND	N/A	This is the system ground. This provides the reference to which signal inputs are measured, and provides a return for power supply.
Pin 5: Channel 1 Three Wire Input	S1 S	Input	This is the input for three wire mode on quarter bridge strain gauge bridges. Leave unconnected for non quarter strain gauge bridge applications.
Pin 6: Sensor Power	SP+	Output	This signal provides output power to external sensors. This output is only active (“on”) when the unit is sampling the sensors. Maximum combined load on this pin and all other SP+ pins is 50 mA.
Pin 7: Channel 2 Sensor Differential Amplifier Input +	S2+	Input	This is the positive input to the channel 2 PGA.
Pin 8: Channel 2 Sensor Differential Amplifier Input -	S2-	Input	This is the negative input to the channel 2 PGA.
Pin 9: Ground	GND	N/A	This is the system ground. This provides the reference to which signal inputs are measured, and provides a return for power supply.
Pin 10: Channel 2 Three Wire Input	S2 S	Input	This is the input for three wire mode on quarter bridge strain gauge bridges. Leave unconnected for non quarter strain gauge bridge applications.
Pin 11: Sensor Power	SP+	Output	This signal provides output power to external sensors. This output is only active (“on”) when the unit is sampling the sensors. Maximum combined load on this pin and all other SP+ pins is 50 mA.
Pin 12: Channel 3 Sensor Differential Amplifier Input +	S3+	Input	This is the positive input to the channel 3 PGA.
Pin 13: Channel 3 Sensor Differential Amplifier Input -	S3-	Input	This is the negative input to the channel 3 PGA.
Pin 14: Ground	GND	N/A	This is the system ground. This provides the reference to which signal inputs are measured, and provides a return for power supply.
Pin 15: Channel 3 Three Wire Input	S3 S	Input	This is the input for three wire mode on quarter bridge strain gauge bridges. Leave unconnected for non quarter strain gauge bridge applications.
Pin 16: Sensor Power	SP+	Output	This signal provides output power to external sensors. This output is only active (“on”) when the unit is sampling the sensors. Maximum combined load on this pin and all other SP+ pins is 50 mA.
Pin 17: Channel 4 Sensor Differential Amplifier Input +	S4+	Input	This is the positive input to the channel 4 PGA.
Pin 18: Channel 4 Sensor Differential Amplifier Input -	S4-	Input	This is the negative input to the channel 4 PGA.

Signal Name	Reference	Direction	Description
Pin 19: Ground	GND	N/A	This is the system ground. This provides the reference to which signal inputs are measured, and provides a return for power supply.
Pin 20: Channel 4 Three Wire Input	S4 S	Input	This is the input for three wire mode on quarter bridge strain gauge bridges. Leave unconnected for non quarter strain gauge bridge applications.
Pin 21: Analog Single Ended Input 5	Ain5	Input	This input is a single ended 0-3 volt input for transducers and/or signal conditioners that provide a high level voltage output. This signal connection is routed directly to channel 5 on the A/D converter. Note: The source impedance should be less than 5K ohms
Pin 22: Ground	GND	N/A	This is the system ground. This provides the reference to which signal inputs are measured, and provides a return for power supply.
Pin 23: Analog Single Ended Input 6	Ain6	Input	This input is a single ended 0-3 volt input for transducers and/or signal conditioners that provide a high level voltage output. This signal connection is routed directly to channel 6 on the A/D converter. Note: The source impedance should be less than 5K ohms
Pin 24: Ground	GND	N/A	This is the system ground. This provides the reference to which signal inputs are measured, and provides a return for power supply.
Pin 25: Analog Single Ended Input 7	Ain7	Input	This input is a single ended 0-3 volt input for transducers and/or signal conditioners that provide a high level voltage output. This signal connection is routed directly to channel 7 on the A/D converter. Note: The source impedance should be less than 5K ohms
Pin 26: Ground	GND	N/A	This is the system ground. This provides the reference to which signal inputs are measured, and provides a return for power supply.
Pin 27: NC	NC		No internal connection
Pin 28: NC	NC		No internal connection
Pin 29: Ground	GND	N/A	This is the system ground. This provides the reference to which signal inputs are measured, and provides a return for power supply.
Pin 30: Power Supply	P+ (Vaux)	Input	Optional power supply, an internal Li-Ion rechargeable battery is built in; however, an external DC power supply can be provided at this pin to replace use of internal battery. The DC supply should be 3.6V to 9V, and capable of supplying sufficient <i>maximum</i> current for the application (usually 20-50 mA, depending on external sensors and node configuration). <b>CAUTION!</b> When using this pin, the internal power switch must be switched.

**Table 2. Pin Numbering, Nomenclature and Use**

## Support

MicroStrain support engineers are always available to expand on this subject and support you in any way we can.

8401-0002 rev 000  
Copyright © 2011 MicroStrain, Inc.



MicroStrain, Inc.  
459 Hurricane Lane, Unit 102 ph: 800-449-3878  
Williston, VT 05495 USA fax: 802-863-4093  
[www.microstrain.com](http://www.microstrain.com) [support@microstrain.com](mailto:support@microstrain.com)

MicroStrain®, V-Link® and mXRS™ are trademarks of MicroStrain, Inc.