

| REV | DESCRIPTION | DATE | APPROVED |
|-----|-------------|------|----------|
| | | | |

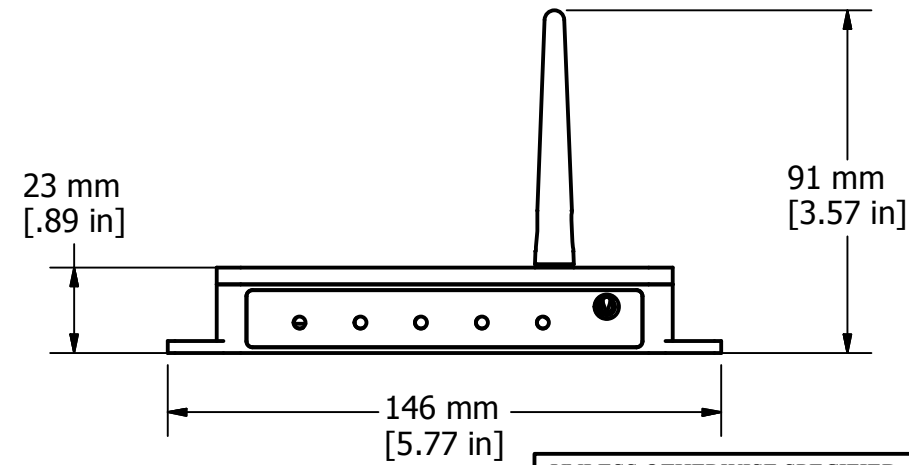
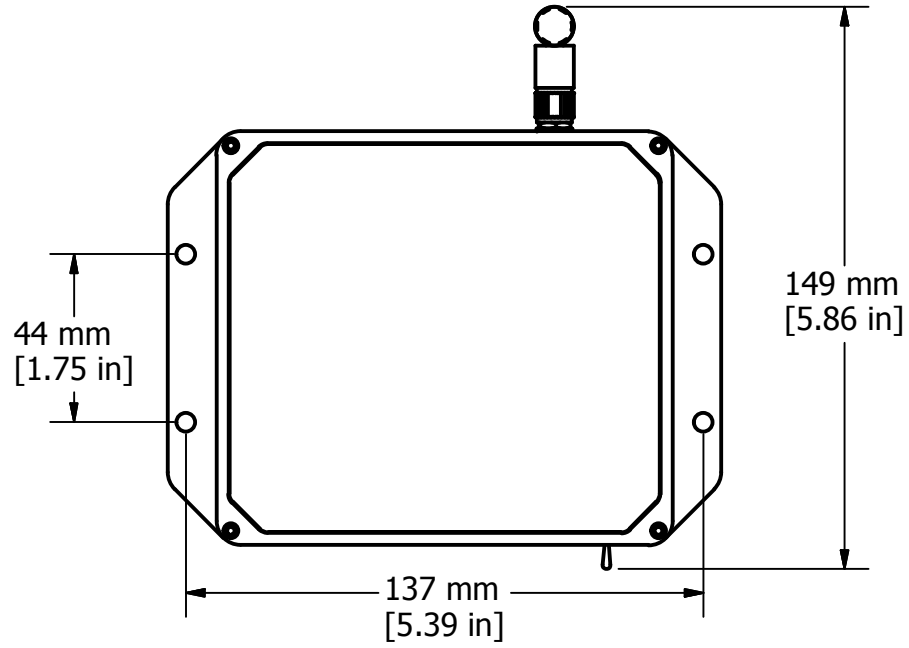

UNLESS OTHERWISE SPECIFIED ALL DIMENSIONS ARE IN INCHES.
 TOLERANCES:(UOS):
 .X = ± .02; .XX = ± .01; .XXX = ± .005
 HOLE DIAMETERS: ± .002; ANGLES: ± 0.5°
 SURFACE FINISH: 63 MICRINCHES
 MATERIAL:
 -

MicroStrain[®] 459 Hurricane Lane, Suite 102
 Williston, VT 05495
 802-862-6629

TITLE
WSDA-1000

THIS DRAWING AND SPECIFICATIONS ARE THE PROPERTY OF MICROSTRAIN INC. AND SHALL NOT BE PRODUCED WITHOUT PERMISSION FROM MICROSTRAIN INC.

| | |
|--------------|------------------|
| DESIGNED BY: | DRAWN BY: TDA |
| CHECKED BY: | APPROVED BY: |

| | | | |
|-----------|--------------------|-----------------------------|--------------|
| SIZE A | CAGE CODE OXYZ9 | DWG NO: 6314-0050 | REV - |
| SCALE 1/2 | | DATE: 1/24/2013 | SHEET 1 OF 1 |

2 1

B B

A A

2 1