

2

1

REV	DESCRIPTION	DATE	APPROVED

B

B

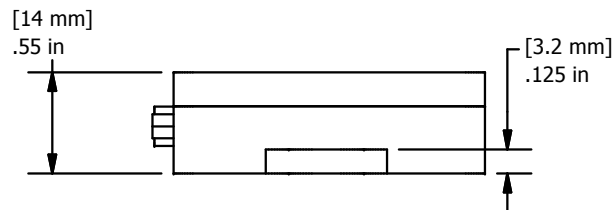
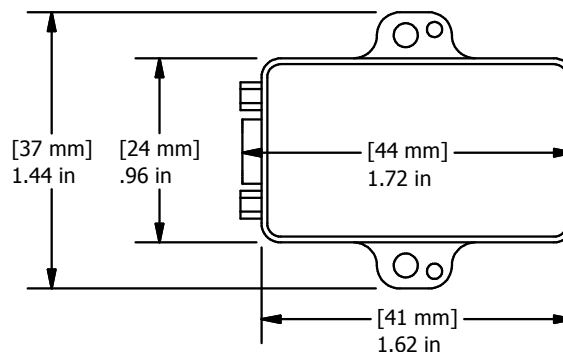
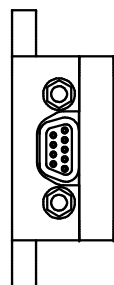
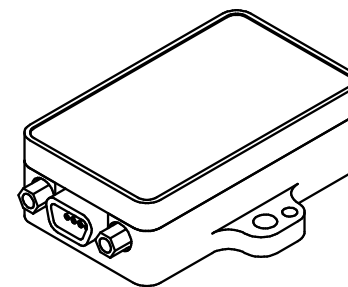

A

A

UNLESS OTHERWISE SPECIFIED ALL DIMENSIONS ARE IN INCHES.
 TOLERANCES:(UOS):
 .X = ± .02; .XX = ± .01; .XXX = ± .005
 HOLE DIAMETERS: ± .002; ANGLES: ± 0.5°
 SURFACE FINISH: 63 MICROINCHES
 MATERIAL: ALUMINUM; BLACK ANODIZED

MicroStrain[®] 459 Hurricane Lane, Suite 102
 Williston, VT 05495
 802-862-6629

TITLE
3DM-GX3-35-RS232/USB-M 5G-300DPS

DESIGNED BY: GCK
 DRAWN BY: RGL

SIZE A	CAGE CODE OXYZ9	DWG NO: 6225-4220	REV 000
-----------	--------------------	-----------------------------	------------

CHECKED BY: BJT
 APPROVED BY: ARD

SCALE 1:1 DATE: 1/14/2011 SHEET 1 OF 1

THIS DRAWING AND SPECIFICATIONS ARE THE PROPERTY OF MICROSTRAIN INC. AND SHALL NOT BE PRODUCED WITHOUT PERMISSION FROM MICROSTRAIN INC.

2

1

